

# Making paper safely

## Managing safety in the papermaking process



HSG279  
Published 2015

This guidance is for managers and users of paper and tissue manufacturing machinery. It provides practical guidance to manage the risks on papermaking machinery and associated tasks and describes the law that applies.

Changes since the last edition:

- This edition updates references to legislation, standards and links to further guidance
- The document has been restructured to cover tasks in papermaking as well as the machine itself
- New sections have been added to cover areas of papermaking machinery/tasks not previously covered
- The machinery section has been restructured to follow the papermaking process

# Contents

## **Introduction 4**

- Background 4
- How to use this guidance 5

## **General guidance 6**

- Risk assessment 6
- Safeguarding machinery 7
- Safe access to plant 17
- Working in confined spaces 20
- Slips, trips and falls 23

## **Tasks performed on papermaking machines 26**

- Safe systems of work 26
- Removing broke 26
- Felt condition monitoring 28
- Fabric changing 29
- Fabric cleaning 31
- Tail- and web-threading 32

## **Stock preparation and de-wiring 35**

- De-wiring 35
- Conveyors feeding pulpers 36
- Pulpers, agitators and stock tanks 39
- Ragger ropes 42
- Cleaners 43
- Refining 44

## **Papermaking machine 46**

- Head box 46
- The wire 47
- Transfer point to press section 49
- Press section 50
- Dryer section 51
- Sizing presses and coating units 53
- Yankee cylinders and through air dryers 54
- Calenders 56
- Reel-ups 58

## **Appendix Updated information on design and implementation of safety-related electrical control systems 61**

- What is a control system? 61
- What is a safety-related control system? 61
- General principles of safety-related control system design 62
- Designing safety-related control systems 63
- Use of standards for safety-related control system 64
- Comparing SILs and PLs 66
- Testing and preventative maintenance 66
- Modifications to safety-related control systems 67
- Programmable electronic safety-related control systems 67
- Non-programmable electronic safety-related control systems 68
- Particular safety functions on papermaking machines 68

**Acknowledgments 71**

**References and further reading 72**

**Further information 76**

# Introduction

## Background

1 This guidance is published by the manufacturing sector of the Health and Safety Executive (HSE). It gives practical advice to employers, managers and users of paper and tissue manufacturing machinery (referred to in the guidance as papermaking machinery).

2 Paper mills and the machinery they use are covered by the Health and Safety at Work etc Act 1974 (HSWA). The Act places general duties on mills to ensure the health and safety of their employees and others. Other regulations made under the Act expand on these general duties covering areas such as machinery, see *Safe use of work equipment: Provision and Use of Work Equipment Regulations 1998. Approved Code of Practice and guidance (PUWER) (L22)*.<sup>1</sup> This publication provides advice on how to comply with the relevant legislation.

3 This guidance identifies the main hazards of the papermaking process in relation to machinery safety and other issues such as housekeeping, access, safe systems of work and confined spaces. It suggests practical control measures to help reduce the risk of injury and can be helpful in carrying out workplace inspections.

4 The guidance does not cover every risk in your workplace or on papermaking machinery. The following health and safety topics are not covered:

- ionising radiation;
- legionella;
- control of fire risks (except in relation to housekeeping); or
- hazardous substances.

Further information on these subjects and the process of risk assessment and more can be found on the HSE website at [www.hse.gov.uk](http://www.hse.gov.uk).

5 This guidance is not intended to be a substitute for a suitable and sufficient risk assessment of papermaking machinery. Dutyholders will still have to ensure that any controls put in place, including those suggested in this guidance, reduce the risks from papermaking processes to an acceptable level. To do this, mills need to know:

- where they are now (standard currently achieved);
- where they should be (benchmark); and
- what is the difference and why (risk gap, see Figure 1)?

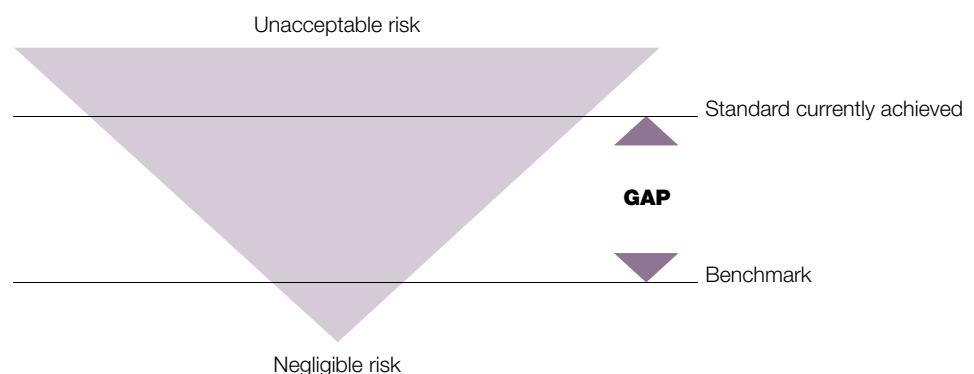

**Figure 1** The 'risk gap' triangle

6 Mills should aim to close the gap between where they are and where they should be by following this guidance and using relevant British Standards. Where mills feel unable to follow the guidance they will need to identify for themselves, through risk assessment, measures to ensure risks are properly controlled.

## How to use this guidance

7 The guidance is broken down into sections. The 'General guidance' section covers broad topics that are found in all papermaking processes including safe systems of work, hierarchy of guarding etc.

8 The sections following 'General guidance' identify the main machine areas and task-related hazards. When applying this guidance you should read the specific machinery section combined with the 'General guidance' section.

9 Some topics such as confined spaces are covered in detail in the 'General guidance' section. Additional measures are specified in the relevant machine section.

10 Within the guidance there are references to British Standards that are relevant to papermaking machinery, see 'References' for further details and 'Further information' for contact details.

11 Where '**must**' is used in this guidance it refers to an explicit legal requirement to take certain action. The term '**should**' indicates what you need to do to comply with the law although you are free to take other action if that would result in compliance.

12 When you see the term 'mills' in the context of what is required, for example 'mills have duties to', 'mills should work towards' etc, it refers to employers and other dutyholders (including employees) in mills.

# General guidance

## Risk assessment

13 As part of managing the health and safety of your business, you must control the risks in your workplace. To do this you need to think about what might cause harm to people and decide whether you are doing enough to prevent it. This process is known as a risk assessment and it is something you are required by law to carry out.

14 A risk assessment is about identifying and taking sensible and proportionate measures to control the risks in your workplace, not about creating huge amounts of paperwork. You are probably already taking steps to protect your employees, but your risk assessment will tell you whether you should be doing more.

15 All papermaking machinery, whether it is new or existing machinery, should be risk assessed to ensure that control measures are implemented to prevent people being injured while working on or around machinery.

16 Concentrate on the real risks – those that are most likely to cause harm. Think about how accidents and ill health could happen and who might be harmed. The following might help:

- Think about your workplace activities, processes and the substances you use.
- Ask your employees, including those who supervise the work what they think the hazards are, as they may notice things that are not obvious to you and may have some good ideas on how to control the risks.
- Check manufacturers' instructions or data sheets for chemicals and equipment, as they can be very helpful in spelling out the hazards.
- Use previous experiences and incidents including procedural violations in relation to each task. Look at past accident and near miss data.
- Some workers may have particular requirements, for example new and young workers, migrant workers, new or expectant mothers, people with disabilities, temporary workers, contractors and lone workers may be at particular risk.

17 Having identified the hazards, decide what to do about them. You don't have to remove all the risks but the law requires you to do everything 'reasonably practicable' to protect people from harm. This means balancing the level of risk against the measures needed to control the risk in terms of money, time or trouble.

18 When carrying out risk assessments you should consider carefully the control measures you put in place. This sometimes means taking a step back from the task and control measures you already have and deciding if there is an alternative way of managing this to get better, safer results. Often the outcome of a risk assessment identifies that personal protective equipment (PPE) or a safe system of work is sufficient to prevent an injury, when in reality a simple change to machinery guarding or task design could prevent an injury.

19 When considering human factors and procedural violations in relation to risk assessment, you may find *Reducing error and influencing behaviour* (HSG48)<sup>2</sup> helpful.

20 Make a record of your significant findings – the hazards, how people might be harmed by them and what you have in place to control the risks. Any record produced should be simple and focused on controls. If you have fewer than five employees you do not have to write anything down, but it is useful to do this so you can review it at a later date, for example if something changes. If you have five or more employees, you are required by law to write it down.

21 When carrying out risk assessments, an approach that doesn't simply accept 'the way we've always done things' is helpful. A different approach that challenges ways in which you have always worked cannot only be helpful in improving health and safety standards but also in improving efficiency and productivity.

22 Few workplaces stay the same, so it makes sense to review what you are doing on a regular basis. Reviewing risk assessments will also help to ensure that control measures previously identified and implemented remain fit for purpose. In addition, after an accident, reviewing a risk assessment can help to ensure any additional control measures that may be required are identified and implemented.

23 Risk assessments that cover machinery, including guarding, control systems and emergency stops etc are often called PUWER risk assessments. PUWER risk assessments can be incorporated into task-based risk assessments to ensure ALL risks are managed.

24 Some examples of causes of machinery accidents in papermaking include:

- inadequate design or construction of machinery;
- the wrong type of equipment used for tasks;
- safeguards removed or fallen into disrepair;
- safety systems overridden or defeated;
- inadequate systems of work;
- inadequate training of operator(s).

25 A risk assessment can help you to identify which of the above hazards may be present on your machinery and also what you need to do to prevent people being injured as a result of them. The risk assessment process should consider both the machine and human factor elements to enable you to make judgements about the level of risk present and the adequacy of controls provided.

26 The importance of risk assessment cannot be stressed too highly. Often the causes of accidents are obvious and should have been identified as part of a systematic approach to risk assessment.

## **Safeguarding machinery**

27 This section provides advice and guidance on the principles of how to guard dangerous parts of machinery on papermaking machines. It sets out the approach PUWER identifies in relation to protecting dangerous parts of machinery. There is more detail later in the publication on specific areas of machinery guarding you may find helpful. As well as covering machinery guarding, PUWER also covers issues such as controls, emergency controls, training and machine maintenance. Following this guidance alone will not ensure mills fully comply with PUWER. More information on the full requirements of PUWER can be found in the PUWER Approved Code of Practice (ACOP).

28 Guidance in this publication relating to machinery guarding applies to both existing and new machinery. However, when buying new machinery you should ensure it complies with the Supply of Machinery (Safety) Regulations 2008 (SI 2008/1597) and any relevant British Standards, see 'Further information'. Further information on PUWER and CE marking is available on HSE's Work equipment and machinery website at [www.hse.gov.uk/work-equipment-machinery/](http://www.hse.gov.uk/work-equipment-machinery/).

### ***Hierarchy of safeguarding measures***

29 PUWER outlines a hierarchy of safeguarding measures which should be used to prevent danger or injury from contact with dangerous parts of machinery. This hierarchy should be used when selecting safeguarding measures for machinery hazards.

30 Risk assessment is the starting point for choosing safeguarding measures. Safeguarding measures fall into a hierarchy of three levels. You should consider each level in turn beginning with the highest level of protection first. Work your way down the hierarchy, making use of the measures as far as practicable. You may need to combine measures from more than one level to reduce the risk. However, your preference should always be to adopt the highest level of safeguarding possible.

31 The three levels of the hierarchy are:

- fixed (enclosing) guards;
- other guards or protection devices, eg interlocking guards, nip guards, guard locking;
- protection appliances, eg trip nip bars (which do not prevent access but stop the movement of the dangerous part before injury occurs and preferably before contact is made) and hold-to-run control devices.

32 The provision of information, instruction, training and supervision is an additional measure to the three levels of the hierarchy and complements each of them.

33 The incentive to defeat or bypass a safety measure increases if the measure slows down production, does not allow the operator to use the machine in a customary way, or it is difficult to use. In designing guards, consideration should be given to how reasonably foreseeable it is that the guard will be defeated or bypassed. Your risk assessment should identify this and specify measures to prevent it happening.

34 Guards can sometimes be used to prevent people accessing danger zones by creating distance. These are known as distance guards and are a control measure that through its height and distance from the danger zone prevents someone reaching round it to the danger point. Distance guards should be high enough to reduce the likelihood of someone climbing over them and low enough to prevent a person crawling under them, although a gap for cleaning is usually allowed. They should also be designed in a way to prevent the guard being used as a way to climb over (eg flat plate rather than handrails). Please check BS EN ISO 13857<sup>3</sup> for details of dimensions and specifications.

#### ***Fixed (enclosing) guards***



**Figure 2** Example of fixed guarding in place to prevent access to the drying cylinders on a paper machine



35 A fixed guard is one that has no moving parts and is fastened in a permanent place around a danger zone. They are either permanently secured in place, eg by welding, or they are secured in place by means of fasteners, screws etc and would need a tool to remove it.

36 BS EN 953<sup>4</sup> introduces the requirement for new machines that any fixings provided for fixed guards shall remain attached to the guard or the machinery when the guard is removed. The underlying logic is that retained (or captive) fasteners will not be lost when the guard is removed, eg for maintenance – so it is much less likely that the guard will be replaced with insufficient fixings, which could allow hazardous parts of the machinery to be accessed. Although this applies to new machinery, you may find it helpful to provide attached fixings for guards on existing machinery to prevent fixings going missing.

37 Fixed guards around dangerous parts of machinery may be designed to have openings to allow limited access, eg for clearing broke, cleaning, feeding paper etc. Openings such as these are allowable as long as the size of the opening and its distance from the dangerous part complies with the safe reach distances in BS EN 13857. These types of guards can be more effective in preventing danger as they allow protected limited access for routine tasks and don't rely on having to replace guards once tasks have been completed. If manual adjustments need to be carried out, it may be possible to extend controls and levers outside of guarded areas so adjustments can be made from a safe position.

#### *Other guards or protection devices*

38 'Other guards' referred to in the PUWER hierarchy include movable guards which can be opened without the use of tools and fixed guards that are not fully enclosing. These allow limited access through openings and gates etc for carrying out tasks such as feeding materials.

39 Movable guards may be power-operated, self-closing, adjustable etc and are likely to require an interlock to prevent the machine operating while the movable guard is open. The exact specification of the interlock should be subject to a risk assessment to ensure the correct level of protection is provided for the area being protected, see Figure 3.



**Figure 3** Example of a movable guard

40 An interlocking guard has a device, usually a switch, which prevents the hazardous machine parts covered by the guard being started up until the guard is closed. Opening the guard will also stop the machine movement, see Figure 4.



**Figure 4** Example of an interlocked guard with trapped key

41 The higher the risk of injury, the more dependable the interlocking system has to be. Two basic designs of interlocking system are normally used on papermaking machinery:

- a system with a single actuator (switch) on the guard and a single control channel; and
- a system with two independent actuators (switches) on the guard with separate control channels to each so that if one fails, the other will continue to work.

42 The second type is used in higher-risk situations. A trapped key exchange system is also suitable for higher-risk applications. For very high-risk situations, dual-control channels with cross-monitoring can be used for the interlocking system.

43 Interlocking with guard locking is required if, on opening the guard, the dangerous parts take some time to run down. Guard locking ensures that the guard cannot be opened until motion has ceased. As a rough guide, guard locking is necessary if the time taken for the dangerous parts to come to rest is more than ten seconds.

44 Protection devices are different to guards as they don't prevent access to dangerous parts of machinery although they are usually used in conjunction with a guard. They are devices such as:

- pressure sensitive mats;
- sensitive protective equipment;
- mechanical trip devices that stop dangerous movements of machinery before a person can contact them.

#### ***Protection appliances***

45 Protection appliances are usually used as an additional control measure to guards and provide a means for an operator to feed loose material into the machine while keeping their body clear of the danger zone. Jigs and holders are examples of protection appliances. These types of safeguard measures are less widely used in papermaking.

#### ***Information, instruction and training***

46 When the risks cannot be adequately controlled through the above hardware measures alone, information, instruction and training can be used to supplement other measures. This safeguard is usually combined with other hardware measures to adequately control risks. When information, instruction and training is used in these circumstances, it is especially important to have a robust training package in place to protect workers.

47 Safeguarding measures need to be carefully designed and provide the required protection without creating unnecessary difficulties for maintenance and production, see BS EN ISO 12100.<sup>5</sup> For design specifications of safeguards such as interlocking devices etc, refer to the relevant ISO, European and British Standards.

### ***Crawl speed***

48 This is the slowest speed at which the machine can run, and according to BS EN 1034-1<sup>6</sup> the speed should be no more than 15 m/min and, depending upon risk assessment, the speed may need to be lowered. (NB on reeler-slitters, the maximum crawl speed should be 10 m/min.) Crawl speed is used with guards removed or inoperative for specific tasks and should only be used with other safeguards in place.

49 There are some jobs, such as inspection, setting up, removing broke and felt straightening, which cannot always be done with the machine stopped. Operating the machine at crawl speed is only regarded as a risk-reduction measure as long as it is combined with a safe system of work, instruction and training to reduce the risks to which the workers are exposed.

50 When removing broke sometimes the machine is run to help remove the wad of paper that has built up to reduce manual handling risks. Wherever possible, this task should be done at crawl speed with a speed no greater than 15 m/min. On machines manufactured or substantially modified before the introduction of BS EN 1034-1, your risk assessment may determine that to remove broke at this speed increases the risk to the operator(s). If this is the case, a slightly increased speed for this task, combined with a safe system of work and trained operators, may be used.

51 Consideration to where the operator will start crawl speed from should be given to ensure they can see the area being worked in and have the ability to stop the machine in the event of a problem. If this approach is used for removing broke, you will need to clearly demonstrate in your risk assessment why this task cannot be done at a slower speed. Your risk assessment should also consider the position of the operating controls in relation to where broke will be cleared.

### ***Hold-to-run control***

52 This is a device which has to be held to allow the machine to run at no more than crawl speed; if the device is released, motion ceases. Running machine sections under hold-to-run control can, for example, be used for removing broke. If the machine can be run in reverse, a hold-to-run control should be provided. The operator should be able to see the danger points from the position of the hold-to-run control device.

### ***Two-hand control device***

53 This is a device that requires two actuators to be pressed at the same time for the machine to operate. If either actuator is released the machine will stop. The actuators have to be far enough apart to prevent single hand operation. This type of control prevents the person operating the machine reaching in to a danger zone when the machine is in motion (crawl speed), see BS EN 574<sup>7</sup> for more information.

### ***Guarding transmission machinery and outer rolls***

54 Transmission machinery can be a hazard at any point along the papermaking machine. They can cause entanglement, crushing, shearing, trapping and impact hazards. All transmission machinery should be guarded unless it is safe by

distance. Rotating shafts present a particular risk of entanglement, particularly if they are slotted or have projections, eg bolts or screws. Fixed enclosing guards or loose sleeves that eliminate the risk can be provided. If there are projections, fixed enclosing guards should be provided.

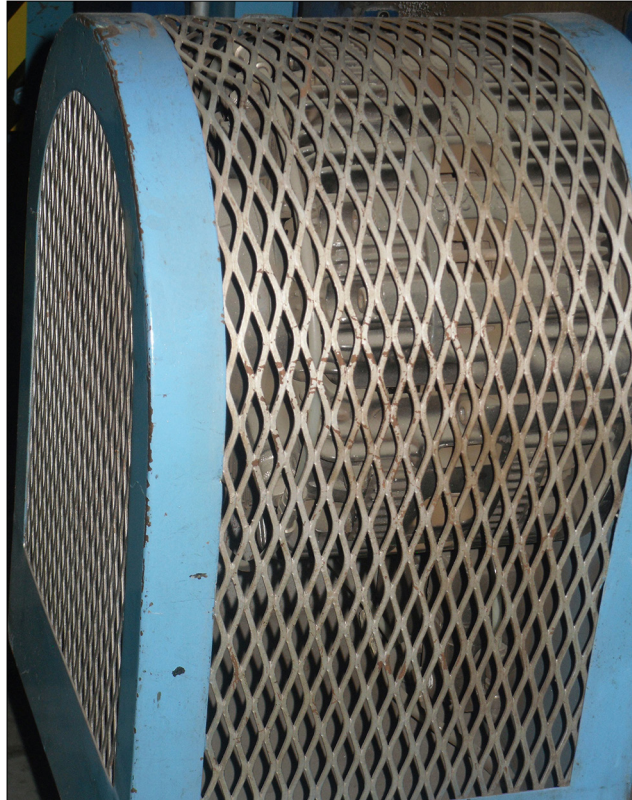

**Figure 5** An example of a fixed guard to protect a rotating shaft

55 It is not acceptable to rely solely on lockable gates at either end of the drive side to guard the transmission machinery of a papermaking machine. If access to this area is required your risk assessment should consider the most appropriate combination of safeguards to protect people. Within the combination of guarding, preference should be given to interlocked gates, key exchange systems and localised guarding to prevent access to dangerous parts. The reliance of human factor-based controls, eg safe systems of work, or a reduction in the machine speed is a last resort. A good risk assessment should examine all the tasks related to working on the drive side of the machine: (Where do people go to work? What do they do when they get there? etc) and identify physical control measures to prevent access to dangerous parts.

56 An 'outer roll' is the part of the roll that is exposed on the outer edges where the wire or fabric does not cover it. Outer rolls can be a wrapping point, which can cause drawing-in, trapping, amputation or death. To prevent this, the first solution is to position the wire or fabric so it doesn't expose the outside edge of the roll. Where this is not possible and there is a wrapping point:

- the wrapping point should be safe by distance and positioned at a height at least 2.7 m above where a person could be; or
- the wrapping point should be guarded by protective structures in accordance with EN ISO 13857, Tables 2 and 4; or
- the wrapping point should be guarded by fixed guards and if frequent access is required, interlocking access guards in accordance with BS EN 1034.

In addition, a warning sign 'drawing-in hazard' should be provided in the area.

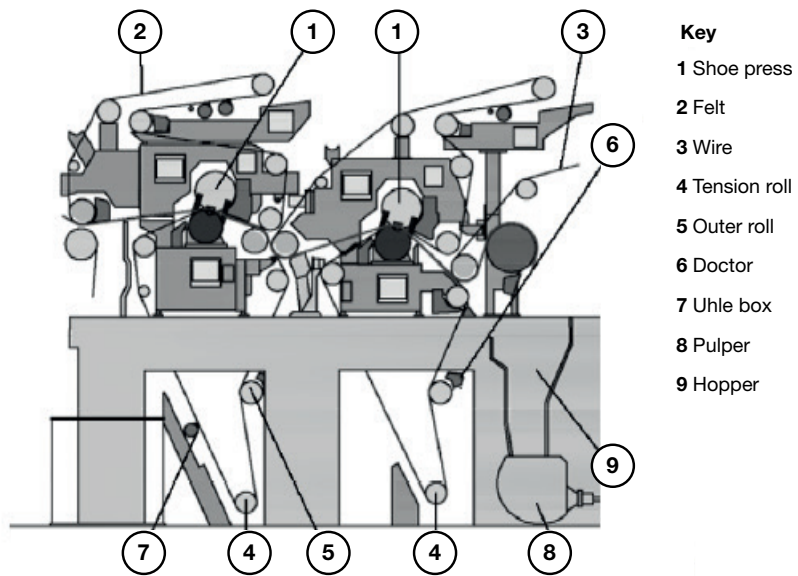

**Figure 6** Example for a press section (safety devices are not shown)

### ***Guarding in-running nips***

57 In-running nips are the main hazard on a papermaking machine. They can be found between:

- rolls rotating in different directions;
- rolls and fixed parts;
- Sheehan ropes and pulleys;
- felts/wires and rolls.

58 There can also be a drawing-in hazard between the rolls and paper if the paper is of a grade where the material is unlikely to tear.

59 In the first instance you should consider whether in-running nips can be eliminated, eg by having a large enough gap between the rotating and fixed parts.

60 Drawing-in on some in-running nips can be prevented by providing an adequate distance between machine parts at the in-running nip point. If an in-running nip can only be reached by an outstretched arm (and not the body), a separation distance of at least 120 mm between machine parts is sufficient to prevent the hazard.

61 Where an in-running nip can be reached by the whole body, the drawing-in risk is prevented if there is a safety distance of 500 mm between machine parts at the in-running nip. On in-running nips where drawing-in hazards cannot be avoided, guards should be provided to protect this area.

62 On papermaking machines some parts are designed to open so-called 'protected nips' for operational reasons. When opened they create other risks that are not protected. Your risk assessment should take this into account and determine what additional safeguards are needed. The solution may be not to use protected nips and fit a guard directly on the nip point.

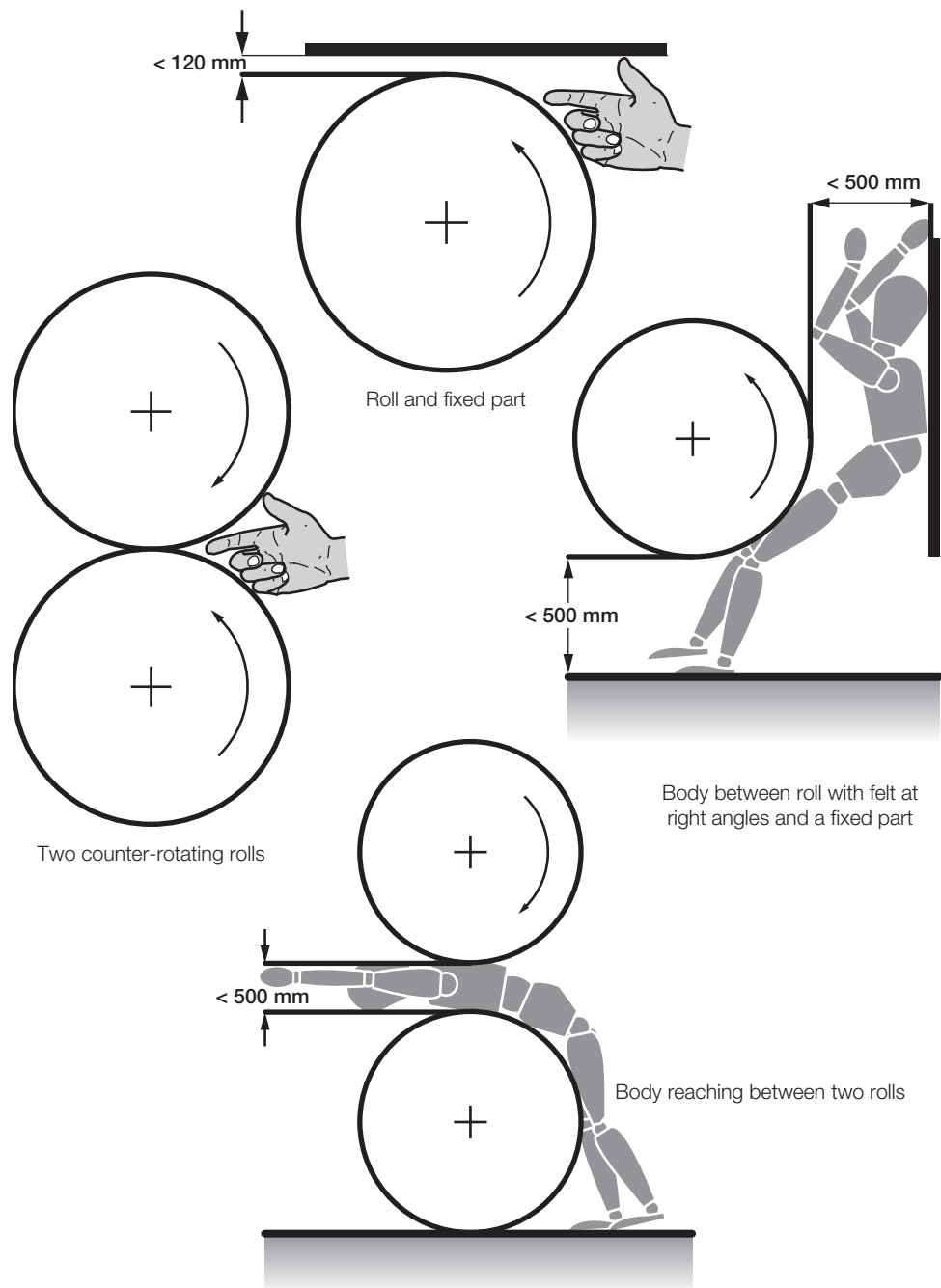

**Figure 7** Examples of in-running nips

**ACCIDENT** - Following a paper break an employee sustained a serious injury to his lower left arm. The injured person was attempting to re-feed the machine following a paper break by tail-feeding. As he attempted to throw the tail into the nip point the paper appears to have wrapped itself around his arm and he was pulled into the machine workings. A safety barrier that was in place was an inadequate safeguard to protect the worker being drawn into the machine. The injured person was released from the machine and given first-aid treatment until an ambulance crew arrived, he was then stabilised and immediately transferred to hospital. The medical staff at the hospital performed a surgical operation which resulted in amputation of the lower left arm at the elbow.

The company were prosecuted and fined £6000.

63 Nip points which are only accessible from the sides of the machine can have fixed guards over the nip point. The guard should extend far enough to prevent someone reaching round it to the nip. BS EN 13857 specifies a reach distance of 850 mm.

64 Nip points which can be reached from passageways, decking, access platforms, catwalks or gangways through the machine should be guarded across their whole width.

65 Examples of nip bars are shown in Figure 8, but alternatives, such as interlocked gates or fixed guarding, may be equally effective. Nip bars provided by round profiled bars are not suitable as they create new in-running nips.

**Figure 8** Examples of nip guards ( $a < 8$  mm)

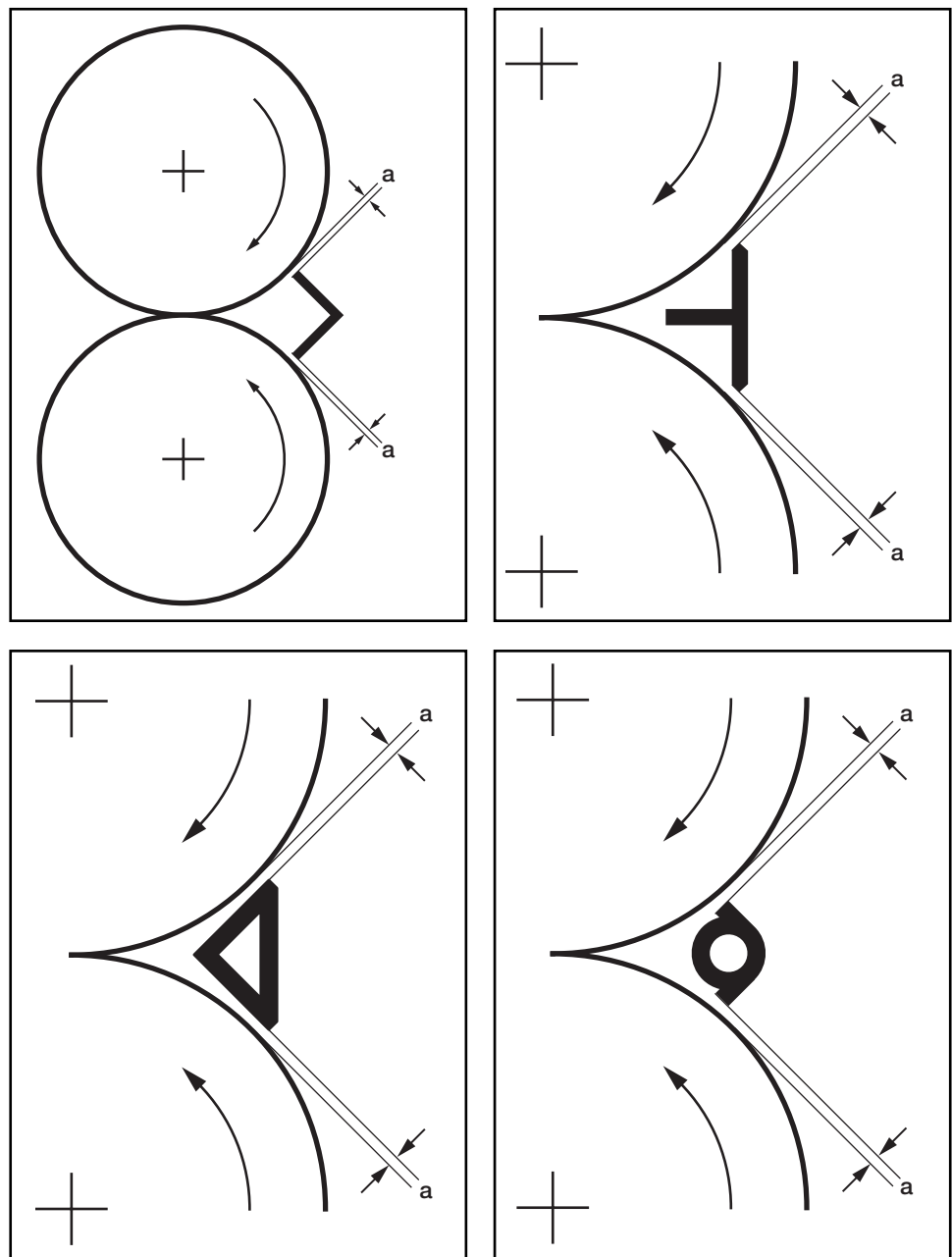

66 The gap between the nip guard and rotating machine parts should be as small as possible and should be no more than 8 mm. The guard should also allow for deflection under operating conditions.

67 All accessible nip points should have safeguarding. When identifying and guarding accessible nip points you should consider nip points away from 'normal' working areas where access is required infrequently. Areas such as these should have local guarding in place or other safeguards in place to prevent access such as interlocked fencing.

### ***Selecting suitable work equipment***

68 Employers should ensure they select the right type of equipment for the tasks they are doing. Consideration should be given to the work environment, the integrity of the equipment and its ability to cope with the task it is being used for.

69 If work equipment is modified, eg it is re-built or adapted to allow it to perform new tasks, you should reassess the suitability of the modified equipment. The assessment should determine if the modified equipment is still suitable for its intended purpose and that none of the changes made will have a negative impact on health and safety. This can be particularly important when modifications include increasing the running speed of a machine or retrofitting items onto equipment that it was not originally designed for.

70 There have been serious accidents and at least one fatal injury as a result of a machine modification. A risk assessment review after a modification is a good way of identifying any new hazards introduced as a result of the modification.

**ACCIDENT** - An operator was fatally injured after being struck by a piece of machinery after looking through a gap in the machine to make sure tissue was being fed through correctly. As he leaned inside the machine, it began to cycle and move a large, two-metre wide reel of tissue into place, striking him on the head. The HSE investigation found the machine had been significantly modified four months earlier so that reels of two-ply as well as single-ply toilet paper could be fed through it. However, this resulted in the creation of a dangerous trap point.

None of the workers at the factory had received training on how to use the machine after it had been modified, or on how to safely check the tissue was being fed through correctly.

Following the fatality the company fitted two sheets of clear plastic over the gap which allowed employees to check the machine without being put at risk.

The company was fined £180 000 and ordered to pay £20 000 in prosecution costs.

### ***Routine maintenance, inspection and testing of safeguards***

71 Any safeguards provided in paper mills including interlocks, electro-sensitive protective equipment etc should be maintained. Checks should also be carried out periodically to ensure they are still in place, in good working order and functioning correctly. Any checks carried out should be recorded.

72 When choosing safeguards, consideration should be given to how easy it will be to access and maintain the measures chosen. If a safety measure cannot easily be maintained or prevents operators running a machine (eg it regularly trips), this can encourage its circumvention or defeat to allow continued use of the machine.



73 There are certain maintenance, inspection and testing tasks in paper mills where it is thought that there is no other option but to do them with machinery in motion and guards removed. Therefore, reliance is placed on risk-reduction techniques and other safeguards to protect workers rather than physical guarding.

74 When considering tasks such as these it is important to challenge whether the task really needs to be done that way. Sometimes a small redesign of the machinery or task can prevent the need to work on moving machinery with guards removed. For example, it may be possible to modify the hardware and/or controls to allow protected access to parts regularly accessed or, to allow adjustment or maintenance from outside the guard enclosure. Other measures such as CCTV, viewing panels or other visual monitoring aids can be used to observe the machine in motion without being inside the guard enclosure.

75 Where the only option is to carry out maintenance on moving machinery with guards removed, other safeguards should be put in place to protect workers. These can include running at crawl speed under hold-to-run control, temporary localised guarding, safe systems of work and the provision of training and supervision.

76 Often contractors are used to undertake maintenance, inspection and testing tasks. The use of contractors on site has to be properly managed. Further information on managing of contractors can be found in *Managing Contractors: A guide for employers* (HSG159)<sup>8</sup> and *Using Contractors: A brief guide* (INDG368).<sup>9</sup>

### **Isolation from sources of energy**

77 Information relating to isolating dangerous parts of machinery from sources of energy is covered in detail in PUWER. Additional sources of information are available on the safe maintenance pages of the HSE website at [www.hse.gov.uk/safemaintenance/permits.htm](http://www.hse.gov.uk/safemaintenance/permits.htm).

## **Safe access to plant**

78 Safe access should be provided to all places where people are expected to work. The European Standard BS EN 1034-1 and the Work at Height Regulations 2005<sup>10</sup> should be considered when determining the best form of access in your mill. Mills should examine where access is required on a regular basis and consider appropriate means of access in conjunction with the job(s) operators are expected to undertake.

### Hazards

- Slips, trips and falls
- Absence of proper walkways to places where people are expected to work
- Excessive physical effort needed, eg to climb a series of ladders
- Falling materials or objects
- Hazards generated by the machine, such as entanglement on adjacent machinery or hot surfaces

### Actions

79 Start by assessing where people need access to and the tasks they will perform there. Once these have been identified it is necessary to select an appropriate means of access in each case. The order of preference for selecting a means of access is as follows:

- Access directly from floor level wherever possible. It is especially important that frequently-operated controls can be reached from ground level.
- If this is not possible or practicable, a stairway may be used, see Figure 9. A stairway should be regarded as the norm for reaching elevated plant.
- If a stairway is not possible, a stepladder or, as a lesser alternative, a ladder, may be considered, see Figure 10. The selection should be made on the basis of risk assessment, which will include an assessment of ergonomics. One or more of the following conditions will need to be satisfied to justify the use of a stepladder or ladder in preference to a stairway:
  - short vertical distance;
  - the means of access will be used infrequently;
  - the user will not be carrying large tools or equipment when using the means of access;
  - only one user at a time is likely to use the means of access;
  - the structure of the machine does not make stairs possible.

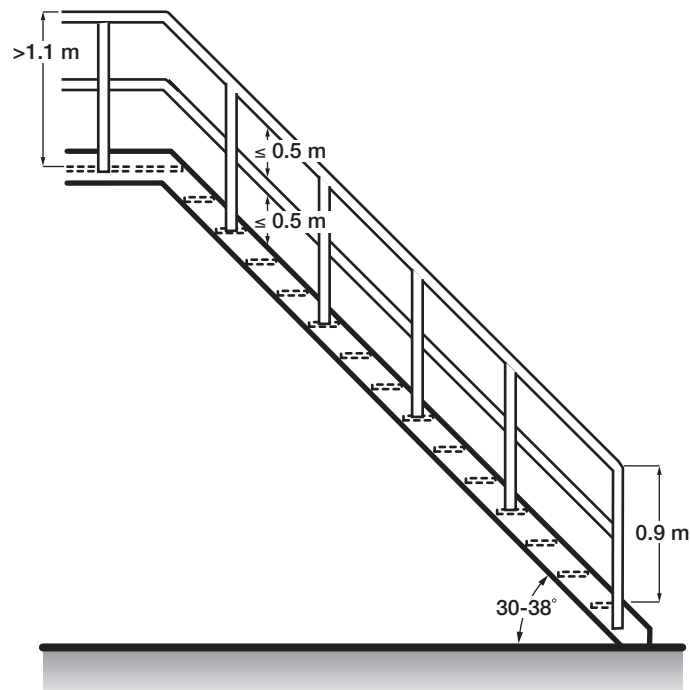

**Figure 9** The main recommended requirements for a stairway access

80 In addition to the requirements in Figure 9, the climbing height of individual flights should not exceed 3 m without a landing. An exception is permitted in the case of a single flight only, which may have a climbing height of not more than 4 m.

81 Where the height of a possible fall is more than 500 mm, the stairway should have a handrail and intermediate rail.

82 If headroom of 2.3 m cannot be achieved along the whole length of the stairway, fit padding to the protruding objects and provide warning signs – remember to provide guarding to prevent entanglement if necessary.

83 The width of the stairway should be increased to 1 m if several people will usually cross on the stairs.

84 Stairways and handrails are not designed as lifting equipment. Do not allow them to be used for slinging or as anchor points for lifting equipment.

85 Where stairways give access to a working area and operators are liable to fall down the stairs, mills have found, through experience, that a spring-loaded barrier that drops into place at the top of the stairs can be very effective to prevent falls.

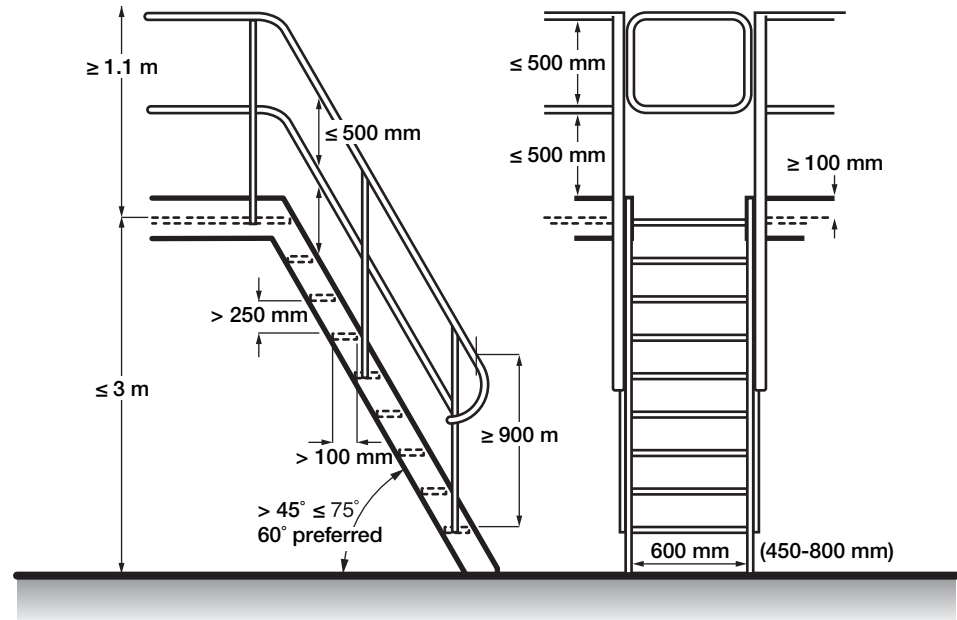

**Figure 10** The main recommended requirements for stepladder access

### Stepladders

86 In addition to the requirements in Figure 10 where the height of a possible fall is more than 500 mm, handrails and intermediate rails shall be provided on both sides. On the same flight, the riser height should be constant. If unavoidable, the riser height of the first step may be reduced by up to 15%.

### Fixed ladders

87 Any vertical fixed ladder over 3 m should be fitted with a vertical fall arrest system (to comply with BS 4211).

88 In addition to the fall arrest system, the spacing between the floor level and the first rung shall be the same as the spacing between the rungs.

89 The top rung should be at the same level as the walking level in the arrival area. If the gap between the walking level and the ladder is more than 200 mm, the floor should be extended to reduce it. There should be a minimum of 230 mm behind each rung to allow room for the foot and provide a firm foothold.

90 A safety cage (hoops) or other type of anti-fall device should be provided where the height of the ladder is more than 3 m. At the arrival area, the safety cage should extend up to the height of the guard-rail on the platform served by the ladder (ie 1.1 m above the platform level).

91 The length of intermediate platforms between two flights of the ladder should be at least 700 mm.

92 The opening at the arrival area should be provided with an inward opening, self-closing gate. The gate should have a handrail at 1.1 m and intermediate rail.

### **Work platforms and walkways**

93 Headroom over platforms and walkways should be at least 2.1 m.

94 As a guide, platforms and walkways should be at least 600 mm wide and preferably 800 mm wide. However, the width and clear length should be determined by such factors as:

- the need for unrestricted work-movements when using tools;
- the number of operators likely to be on the walkway or platform at the same time;
- the frequency and duration of the tasks undertaken;
- people passing each other etc.

95 Where you could fall 500 mm from a platform or walkway, provide handrails at a minimum height of 1.1 m above the platform with an intermediate rail and toe board. The maximum gap between the handrail and intermediate rail, and between the intermediate rail and toe board should be 500 mm.

96 Do not allow handrails or intermediate rails to be used as a means of access to a higher level.

97 Securely fasten open-grid flooring to the framework.

98 If a section of flooring in a working platform or walkway has to be removed, for example, when changing a felt, erect temporary protection around the opening and put up a warning notice. Make sure that there is a system of work for replacing the flooring when the job is completed and that the person(s) responsible knows that it is their job to do it.

99 If temporary access platforms are required, ie for non-routine maintenance work, a competent access contractor should be used to provide scaffolding or supply a mobile elevating work platform (eg a 'Cherry Picker').

### **Working in confined spaces**

100 A confined space is one which is enclosed, or largely enclosed, and that has a reasonably foreseeable risk to workers of fire, explosion, asphyxiation, drowning (either in a fluid or free-flowing solid) or loss of consciousness due to heat.

101 It may be small and restrictive for the worker or it could be far larger, such as a storage tank. Examples include:

- drying cylinders;
- reaction vessels;
- enclosed drains;
- sewers;
- areas where oxygen levels are deliberately reduced, eg to avoid fires or to prolong food shelf life.

102 Less obvious examples include:

- open-topped chambers;
- vats;
- combustion chambers in furnaces etc;
- ductwork;
- poorly ventilated areas.

103 Some may be confined spaces for limited periods of time, usually due to the work being conducted within the space such as:

- rooms used for spray painting or chemical coating;
- spaces where welding or some other process affects the oxygen content of the environment;
- places where chemicals or solvents are being used, eg for cleaning purposes.

#### Hazards

- Lack of oxygen (eg arising from rust forming in tanks when unused for a period of time)
- Entry of poisonous gas, fume or vapour from connecting pipes
- Water, stock or other liquid suddenly filling the area (eg from fluid reservoir)
- Hot and humid conditions leading to a dangerous increase in body temperature and heat stress
- Vapours fume and gas from work being carried out within the space (eg welding, spray painting/coating or cleaning using solvents)

104 The hazards identified relate directly to the confined space and not to other risks that may be present, eg slips and trips, manual handling etc.

#### Actions

105 The starting point for managing the risks of confined spaces is to identify the areas and plant in your mill which fall within the definition of the Confined Spaces Regulations 1997.<sup>11</sup> This may include not only plant with limited openings, such as drying cylinders, head boxes and closed-top pulpers, but also open-topped vessels where, for example, there is a risk of drowning from the failure to isolate the in-feed of liquid.

106 Once you have identified all confined spaces, the next step is to carry out an assessment to determine control measures to reduce the risks. The Regulations state that a worker should not enter a confined space if the work can be carried out in some other way. When assessing your confined spaces you should identify which tasks can be carried out without the need to enter the confined space, eg using cameras for inspections.

107 Where entry cannot be avoided, you need to assess the risks and control them. In paper mills heat stress can be a particular problem and so should be considered in the confined space risk assessment. The assessment should also cover other risks in the area, eg mechanical movement caused by stored hydraulic pressure, stopping machinery moving when someone is inside, or slips, trips and falls.

108 A competent person should be given responsibility to ensure that the necessary precautions are taken. This is someone who understands the Regulations, the work to be done, the environment in which it will be done and the risks associated with the task.

109 Use a safe system of work for entry into confined spaces and support this with a permit-to-work to ensure that safeguards to deal with the risks are in place before the work can start.

110 Emergency arrangements for getting someone out of the confined space should be in place before work begins. You cannot rely on the emergency services. Rescuers will need to be trained in procedures and the use of rescue equipment.

They will also need to take part in regular emergency exercises to test the arrangements. Examples of rescue methods include:

- lifelines attached to harnesses;
- self-rescuers;
- mechanical oxygen;
- breathing apparatus;
- trained rescue teams;
- lifting cushions to raise a person to the height of exit and a lifeline.

111 Consider the following points when drawing up a permit-to-work system/safe system of work for entry into confined spaces:

- **Appoint a competent person** – They should take control and be in charge of the work. Set out their responsibilities so that they know exactly what they have to do. State the precautions that have to be taken before the work starts, and how often and at what stages they have to carry out checks. Decide the level of supervision required.
- **Assess the person identified to enter the confined space** – You should consider their age, size, fitness and general medical condition. For example, if they have to use breathing apparatus they need to be sufficiently fit to carry the weight of that equipment in that particular task. They should be trained to carry out the work in that environment.
- **Isolations** – Establish what isolations are needed before entry. Remember that all sources of energy (not just electrical sources) and in-feed of liquids etc need to be isolated. Turn the equipment off and ensure it cannot be switched on again accidentally if accessing machinery, for example when carrying out maintenance or repairs.
- **Heat stress** – Where people entering the confined space may be exposed to heat stress, the system of work should set out the length of time a person may remain inside and the frequency of rest periods. This will depend on the amount of physical effort involved in the work, see [www.hse.gov.uk/temperature/heatstress/riskassessment.htm](http://www.hse.gov.uk/temperature/heatstress/riskassessment.htm).
- **Securing cylinders** – In the case of entry to drying cylinders, establish the means for securing the cylinders to prevent them turning under their own inertia with someone inside.
- **Air testing prior to entry** – Decide the procedure for testing the air and take action to tackle any risks, eg providing required respiratory equipment, ventilation.
- **Ventilation** – Decide whether ventilation should be improved, eg by opening other access doors or providing mechanical ventilation. Ensure that the measures you take don't increase the risk, eg using petrol driven ventilating equipment if the exhaust fumes are likely to enter the confined space.
- **Risks of the work being done** – Consider whether any risks will arise from the work being done, eg fumes from welding and what steps need to be taken.
- **Electrical issues** – Electrical lighting and tools inside metal tanks and cylinders need to be extra-low voltage (typically 25 V). Consider the use of air tools instead.
- **Communication** – Decide how communication will be maintained between people inside the confined space and those outside. This is particularly important in an emergency situation. You should test your communication method to make sure it works when the person is in the confined space.
- **Emergency provisions** – Assess what emergency provisions are needed, eg how a worker that is injured or overcome will be recovered from the space and treated.
- **Contractors** – Remember that you will need to ensure that contractors follow your site rules. More information on managing contractors can be found in *Using Contractors: A brief guide*.

112 For more information, see HSE's confined spaces website at [www.hse.gov.uk/confinedspace/](http://www.hse.gov.uk/confinedspace/).

## Slips, trips and falls



**Figure 11** Areas around the paper machine, including the basement, should be kept clear at all times

113 Remember that slips, trips and falls account for a significant number of accidents in paper mills and can represent a huge personal and financial cost.

### Hazards

Slips, trips and falls due to:

- inadequate cleaning
- hose reels/trailing cables
- poorly designed and maintained floors, stairways and access platforms
- wet or contaminated floors – particularly in combination with paper dust and chemicals
- spillage of chemicals, eg oil, starch, retention agents
- the accumulation of dust and debris
- trip hazards caused by removal of plant and fixtures, eg fixing bolts left sticking up from the floor when machinery is removed
- inappropriate footwear for the task and environment

### Actions

114 In most instances the implementation of a robust housekeeping, maintenance and cleaning policy will help to eliminate slips, trips and falls. Reducing the likelihood of slips, trips and falls in the workplace relies upon setting standards and a commitment to maintain those standards at all levels, from boardroom to shop floor.

115 Mills should set out standards they want to achieve in reducing and managing the risks of slips, trips and falls. A clear plan should be in place outlining how you intend to achieve this. Most importantly you should allocate resources to ensure the targets are met.

116 Outlining responsibilities at all levels for managing slips, trips and falls is an important part of managing and reducing the risks. This will include day-to-day housekeeping activities, planned and non-routine activities, cleaning regimes, responding to situations as they arise, inspection and maintenance of floors, reporting defects and allocation of responsibility to action reports of defects etc.

- 117 Where equipment for managing the risks of slips, trips and falls is identified, eg spill kits, vacuums and anti-slip paint they should be made available to respond to situations as they arise.
- 118 Consideration should be given to those who do not work directly for you to ensure they understand and comply with the slips, trips and falls standards you have in place, eg not leaving tools or materials where a person could fall over them, or cleaning spillages as they occur.
- 119 Provide a regular regime to keep on top of cleaning. The frequency of cleaning will depend on the product being made and the level and type of contamination in the workplace. It is also helpful to prioritise areas and activities that you have identified, from analysing accident data or from risk assessments, that will need to be cleaned more often. These could include machine hoods, ductwork, building ledges etc. Some mills have adopted the 5S programme (Sort, Set in Order, Shine, Standardise and Sustain) to help achieve a high standard of housekeeping.
- 120 A clean-as-you-go procedure should be in place for spills and general day-to-day housekeeping tasks.
- 121 Where possible, clean down should be carried out at the end of shifts using water hoses, vacuum cleaners or brushes. The use of air lines for cleaning purposes can create additional hazards and can make cleaning less effective.
- 122 Keep hoses coiled or off the floor when not in use – preferably fit automatic retraction systems.
- 123 Site electrical power points, air lines and water hoses close to where they need to be used to avoid long lengths of pipe/cablling.
- 124 Give careful consideration to other hazards, eg working at height and mechanical hazards that staff may be exposed to when following slips, trips and falls standards. You should ensure you have all the necessary safeguards in place to protect staff, eg isolation, access equipment.
- 125 Check floors for loose finishes, holes and cracks etc, and deal with defects promptly. Provide adequate drainage to prevent standing water and growth of slime.
- 126 Mark out through-routes which take people away from slippery areas.
- 127 Warn of changes in floor level, particularly at the beginning of a ramp, eg by painting a hatched area on the floor, and make sure the area is clearly lit.
- 128 Design flooring, platforms and stairs to reduce slips, trips and falls risks, eg use appropriate flooring for the environment and tasks in the area, taking into account the slip resistance required; demarcate the edge (nosing) of stairs; ensure stair depths are evenly spaced; and provide easily accessible handrails where necessary, eg on stairs or ramps.
- 129 If other materials are to be applied to floors, eg paint to demarcate walkways, consider the effect this will have on the slipperiness of the flooring. It may be necessary to add aggregates to the material to maintain the slip resistance of the floor, eg adding sand to paint.
- 130 The cleaning regime has to be right for the floor surface – incorrect cleaning techniques can reduce the slip-resistance of the floor.



131 Cleaning methods will differ according to what has been spilled – make sure operatives are properly trained in the right method. For example, cleaning a spillage of starch with water will make the slipping hazard worse.

132 If in doubt, consult a reputable flooring or cleaning product manufacturer for the cleaning method most suitable for the floor, and type of contamination expected.

133 When providing footwear, consideration should be given to the slip-resistant properties of the shoes for the environment they are working in.

134 More information on managing slips, trips and falls in the paper industry can be found in the HSL Paper and Board Industry Advisory Committee (PABIAC) report which can be found at [www.hse.gov.uk/paper/slips-falls-summary-pabiac.pdf](http://www.hse.gov.uk/paper/slips-falls-summary-pabiac.pdf).

# Tasks performed on papermaking machines

## Safe systems of work

135 Safe systems of work are formal procedures or methods of working. They are needed when guarding of dangerous parts cannot eliminate all of the hazards and some element of risk remains. Safe systems of work should not be used as a substitute for guarding.

136 Before a safe system of work can be developed, a risk assessment that looks at the task and associated hazards should be completed. Once the risk assessment is complete, a safe system of work can be drawn up identifying how the task should be carried out, the risks involved and the precautions to take to reduce the risk. The safe system of work should then be communicated to those carrying out the task and their supervisors.

137 Safe systems of work commonly fail for one or more of the following reasons:

- the system is irrelevant or impractical – it was drawn up in isolation, without consultation, by someone who is not involved in managing or using the system;
- failure of communication – the system is introduced without people being trained in it or having it explained to them;
- failure of supervision – those in charge are not familiar with the system or do not enforce it;
- following the system takes too long – if the time and effort involved in following the system is out of proportion to the time the job would take, people working under pressure are often tempted to take the easier and quicker option of a short cut.

138 Remember, you need to design tasks and controls to ensure that ‘the easy way is the safest way’.

139 Once implemented, the safe system of work should be monitored to make sure that employees (particularly new ones) and contractors are familiar with it, follow it and that it is workable. It is recommended that systems of work are covered by site inspections or management audits. The risk assessment can help decide how and when the safe system of work should be monitored, eg high-risk activities may need checking more frequently and in greater depth than low risk activities.

## Removing broke

140 Removing broke is a common task on a papermaking machine that has resulted in injuries. (Broke includes ‘wads’, also known as ‘plug-ups’, and ‘wraparounds’.)

### Hazards

- Trapping or entanglement in moving machinery
- Musculoskeletal injuries due to pulling heavy loads of broke from the machine
- Being struck by tools used to remove broke while the machine is in motion
- Exposure to static electricity discharges
- Heat stress during removal of broke
- Burns from hot surfaces such as cylinders

## Actions

141 Safe broke removal relies on a combination of well-defined and practised safe systems of work, and physical control measures that have been implemented as the result of a risk assessment. The assessment should consider safe means of access into the machine and other safeguards that need to be in place during broke removal.

142 Where possible, automatic broke-removal systems should be provided. If it is not possible to provide automatic systems, broke should be removed from a stopped machine, unless the machine is designed to remove it while running. Only if the machine cannot be stopped and/or automatic cleaning equipment cannot be fitted should cleaning take place on moving rolls. In these circumstances, crawl speed, hold-to-run controls, distance guarding and appropriate tools to remove broke without entry into the machine should be considered within your risk assessment prior to allowing close access to moving machinery.

143 The following are some of the issues you need to consider in implementing your systems of work:

- all employees involved in broke removal should be trained in the safe system of work;
- all rolls on a machine should be capable of being stopped;
- provide ergonomically designed tools, eg a broke hook or air knife to allow broke removal with the machine stopped and from outside guards eliminating the need to enter the machine;
- permanent or temporary guarding provided should comply with reach distances in BS EN ISO 13857;
- isolation and lock-off procedures should be in place for entry into the machine and include isolating the section being worked on and the sections either side;
- hold-to-run controls should be located so the operator can see the danger zone and machine movement should stop as soon as the control is released;
- if reverse gear is used for cleaning or broke removal, new danger points can be created. If new danger points are created, reverse should be done under hold-to-run control;
- if a roll or cylinder has to be rotated to remove broke, hold-to-run at crawl speed should be used;
- provide earthing or other anti-static measures to dissipate static electricity;
- protection from hot surfaces should be provided either locally or through PPE;
- appropriate access to height should be provided if carrying out broke removal at high levels;
- if removing broke from low felts/fabrics in basements, these may be confined spaces and the procedures in *Safe work in confined spaces* should be followed.

144 Removing broke is a physically demanding task and manual handling injuries can occur. To reduce the risks, a manual handling assessment should be completed. It should consider issues such as: removing the wad by mechanical means, eg rotating the cylinder or by automatic removal systems; providing lightweight ergonomically-designed broke removal tools; consider team handling and job rotation to reduce the amount of time a person is involved in the task; and providing manual handling training that is tailored to the task.

145 Broke removal is sometimes carried out in warm surroundings, which combined with physical activity, can lead to heat stress. This should be considered in your safe system of work and may include measures such as:

- allowing hot surfaces to cool before intervening;

- restricting the length of time individuals are involved in the task; and
- providing regular breaks and drinks to replenish lost fluids.

More information can be found on the heat stress pages of HSE's website at [www.hse.gov.uk/temperature/heatstress/](http://www.hse.gov.uk/temperature/heatstress/).

146 Once broke removal has been finished a check should be made to ensure all fixed and/or interlocked guards are back in place and fully functional.

## Felt condition monitoring

147 Felt condition monitoring is sometimes used as a proactive way of identifying issues with the fabric that can affect production and quality. Control measures will need to be carefully considered before any felt condition monitoring takes place.

### Hazards

- Drawing in and entanglement in moving machinery or felt when using hand-held diagnostic equipment
- Crushing and shearing on traversing systems between diagnostic equipment and fixed parts of the machine
- Falls from height
- Musculoskeletal injuries due to handling large, awkward or heavy materials or equipment
- Inadequate lighting causing safety issues

### Actions

148 Automatic scanners and measuring devices significantly reduce the risk of felt condition monitoring as they do not require a person to physically take measurements. However, you should ensure that any automatic system is properly guarded so it does not create any additional mechanical hazards. You should also ensure the device is linked into the paper machine's control system so it does not operate when the machine is shut down or when people intervening with the machine are at risk. The standard BS EN 1034-16<sup>12</sup> provides more guidance on control measures for these types of measuring devices.

149 Where hand-held devices are used, safety measures will need to be agreed to prevent a person contacting the rotating fabric or rolls. Such measures can include:

- providing a protected area for felt condition monitoring to take place;
- providing a frame for supporting the measuring equipment, this could be a fixed rail that the device can be attached and manually manoeuvred across the face of the felt;
- providing an extended handle to move the device to help distance people away from the moving machinery and felt.

150 Other considerations include:

- providing localised lighting in the work area, as often overhead lighting does not reach into areas being accessed;
- providing access platforms for high-level monitoring points;
- providing additional guards for mechanical hazards normally out of reach when working at height.

151 When felt condition monitoring is being carried out you should have robust systems in place to ensure that any hazards are removed from the area and that operators are informed of the work and its location. Consider periodically monitoring the person carrying out the work.

## Fabric changing

152 Fabric changing is a hazardous task and involves a number of staff working together as a team to remove the old felt and replace it with a new one. There are generally two different types of felts that can be used – seamless and seamed. There are hazards that are common to changing both types of felt and there are some hazards that are different or more or less severe depending on the type of felt and paper machine used.

### Hazards

- Entanglement in moving machinery
- Entanglement in the fabric or other material being removed or fitted
- Falling from height
- Being struck by tools or materials falling from above
- Musculoskeletal injury due to handling large, awkward or heavy materials or equipment
- Working under suspended loads
- Failure of lifting equipment used
- Cuts from sharp tools used to seam or trim fabrics
- Failure of communication between team members

### Actions

153 Fabric changing should be carried out under the control of an experienced, competent person. The competent person should ensure that the safe system of work developed as the result of a risk assessment is followed and that any control measures are implemented. The system of work should consider all aspects of the work including how to deal with heat stress, exhaustion and shift changeovers as fabric changing is a lengthy process that can span more than one shift. In these instances communication is very important.

154 Fabric changing should only take place on a stationary, isolated machine. However, if absolutely necessary for certain parts of the fabric changing process, the machine should only be allowed to move under strictly controlled conditions defined within the system of work, and at a maximum of crawl speed and preferably, hold-to-run control.

155 The safe system of work should consider:

- where the fabric may snag, eg pipes, equipment and identify ways to eliminate the hazard, eg by rounding surfaces or removing/modifying snagging points;
- a suitable means of support for fabrics while they are unrolled to be put into place;
- precautions to stop cylinders rotating freely while being worked on;
- effective communication channels between team members, eg radios may be needed as workers could be anywhere on the machine;
- the control position for the operator to ensure they have line of sight of others involved in the process or can communicate with them;

- areas where there are suspended loads and controls that may need to be implemented (more information on suspended loads can be found on the HSE website at [www.hse.gov.uk/work-equipment-machinery/planning-organising-lifting-operations.htm](http://www.hse.gov.uk/work-equipment-machinery/planning-organising-lifting-operations.htm));
- requirements for maintaining and inspecting lifting equipment, see *Safe use of lifting equipment. Lifting Operations and Lifting Equipment Regulations 1998. Approved Code of Practice and guidance (L113)*;<sup>13</sup>
- providing purpose-built or designed into the machine jacks or winches if they are used;
- providing additional supports, eg stands or blocks if rolls need to be suspended for any length of time;
- precautions when straightening fabrics, including running the machine at crawl speed;
- control measures to reduce manual handling risks, eg providing lifting aids and training staff (see Figure 12).

156 Fabric changing often involves working at height while manoeuvring the fabric, tools and equipment. Therefore providing a safe means of access for operators to carry out tasks safely is very important. Safe access may mean providing more than one access point to allow operators to access all areas they need to. Primarily, temporary (or permanent) access platforms should be built in the areas operators will need to get to. In areas where it is not possible to provide access platforms, a risk assessment should be carried out to identify appropriate alternative means of access that take into account the nature of the task. More information on working at height and can be found on the HSE website at [www.hse.gov.uk/work-at-height/index.htm](http://www.hse.gov.uk/work-at-height/index.htm) and also in *Working at height: A brief guide (INDG401)*.<sup>14</sup>

157 During fabric changing it may be necessary to remove sections of walkways and handrails to allow access for the fabric replacement. Where openings have to be left unattended, appropriate temporary barriers and signs should be erected. All handrails and walkways should be replaced after work is completed and before normal operations recommence. Walkways and floors should also be checked for tools, materials or spillages.

158 Once the fabric changing process is complete and before production starts again, thorough checks of the machine should be carried out to ensure all safeguards, such as fixed guards, walkways, platforms, interlocked guards are in place, fully secured and functional.



**Figure 12** Examples of devices that could be used to pull the felt into position.

## Fabric cleaning

159 Fabrics are periodically cleaned to remove contaminants than can affect paper quality and reduce machine run-ability. Depending on the contaminant and it's properties, eg dust, grease, particle size there are a number of cleaning methods which can be used including:

- air shower;
- water shower (high pressure);
- steam shower (high pressure);
- hot water shower (low pressure);
- chemicals (low pressure);
- brush.

### Hazards

- Entanglement in moving machinery
- Entanglement in the fabric
- Burns from hot surfaces or steam
- Injury as a result of falling from height
- Chemical burns
- Musculoskeletal injury due to handling large, awkward or heavy materials
- Slippery or wet conditions
- Chemical fumes causing loss of consciousness

### Actions

160 When choosing and installing fabric cleaning systems on paper machines you should consider additional hazards that can be created by the installation, eg nip points between fixed bars on the cleaning machinery and the moving fabric. This should be done as part of the risk assessment process to identify who might be harmed and how. As well as considering physical safety measures on the machine in your assessment you should also consider tasks that are carried out as part of the cleaning process. Any control measures identified, eg guarding, safe systems of work etc should be implemented. The risk assessment should consider at least the following issues:

- location of controls to operate cleaning systems, eg to reduce the need to work at height, locate them at floor level;
- safe access into machinery through guards including providing fixed and/or interlocking guards below dryer sections;
- isolation and permit-to-work procedures, eg before accessing the basement to remove broke;
- how doctor/coating blades will be removed and stored;
- chemical dosing and application procedures including appropriate PPE for different tasks;
- confined space entry;
- segregation/communication of areas being cleaned to operators, eg cordoning off areas such as the drive side, upper platforms etc and providing warning signs;
- manual handling, eg using mechanical lifting aids to remove paper from the basement;
- contact with hot surfaces, eg waiting until surfaces have cooled down, providing gloves, gauntlets, long sleeved clothing.

161 It is likely safe systems of work will identify the need to undertake preparatory work before the fabric is cleaned, eg removing broke from under dryer sections. Once preparatory tasks are complete it is important to ensure that all operators are

clear of the papermaking machine and that all guards are properly reinstated, secured and functional before moving onto the next stage of the cleaning process. It is also important to ensure that steps have been taken to prevent access underneath the dryer section from the basement during cleaning.

162 If chemical fabric cleaning is to be carried out, all guards should be reinstated and then the machine should be run at the slowest possible speed. Ideally this should be at crawl speed, but the process on older machines (prior to the European standards for papermaking machines) may mean an increase above crawl speed. If this is the case, the fabric should only be allowed to move under strictly controlled conditions that are specified within the system of work. If jet washing is to be carried out, guards should be reinstated and then safe systems of work should identify how to proceed with this work safely.

163 There are new cleaning systems that can be retrospectively installed within the machine frame for fabric cleaning. These systems are designed to run at full speed with all the guards in place and are controlled from the operating floor. When using systems such as these, it is important to follow the manufacturer's guidelines. You should ensure when installing them that no additional health and safety hazards are created and that safe systems of work are agreed prior to them being used.

164 During cleaning the hood doors should be kept closed with the hood extraction fans running to avoid fumes which could result in unconsciousness and exposure to chemical splashes. Access to the hood area should be prevented at all times during the cleaning operation.

165 Once fabric cleaning processes are complete you should check to make sure the machine is operating as expected, that all guards etc are in place and functional and that the floor area is cleaned of any residual water.

## **Tail- and web-threading**

166 Tail- and web-threading systems are a combination of devices that are used to feed a narrow tail of the web from one machine section to the next, up to the reel section. The web is then gradually widened until it spans the full width or deckle of the machine. There are a number of common factors that affect the selection of the tail-feeding system chosen that include:

- machine speed – extremes of high and low speeds, multi-speed and the requirement to slow down to thread;
- machine configuration – alternate threading requirements, long draws and vertical or inverted paths, location of tail nips;
- product characteristics – fragile (tissue) or high tensile strength;
- inconsistent threading performance – between shifts, individual operators or as a consequence of differing operating conditions;
- machine efficiency – tail width, tail stability, double tails, broke capacity limitations, location of tail nips.

167 No one piece of tail-feeding technology can be applied throughout a paper machine, a combination of measures which can deal with the unique characteristics of the machine and product at each site will normally be required.

168 Tail-feeding systems are combined with tail-cutters or choppers, using water-jet technology or rippers to complete the task. Different types of tail-feeding technology include:



- fully automatic systems;
- semi-automatic systems including:
  - rope – uses ropes and sheaves (pulleys) and can be easily integrated as part of a combined system. Can have significant maintenance requirements and correct set up is critical;
  - air trays (see Figure 13) – use compressed air to direct the tail over a tray. They are best used to direct the tail over short distances in combination with other technology;
  - air tubes – use compressed air to direct the tail along a tube often used for light grade paper or tissue;
  - conveyor – use compressed air to create a vacuum. Can have high maintenance requirements for the fans and ducting;
  - ropeless – includes a range of alternatives to ropes including airguns, foil technology and vacuum rolls;
- manual feeding.

#### Hazards

- In-running nips between ropes and pulleys of Sheehan rope system
- Hand-feeding into machine roll nips
- Hand-feeding into reel-ups
- Fire from friction on broke build-up around nip bars
- Hazards from compressed air
- Mechanical hazards of conveyors

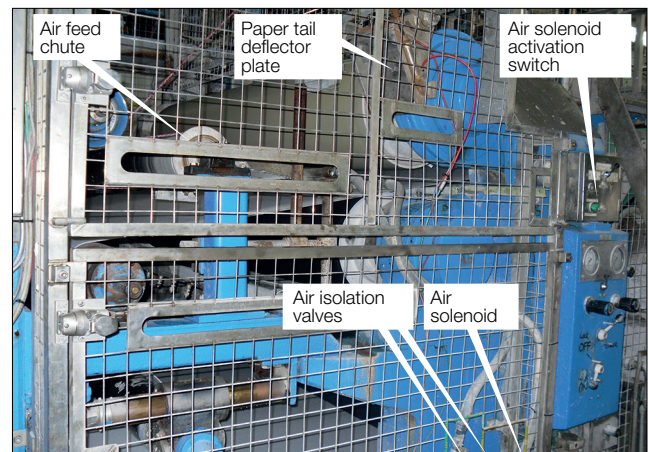

**Figure 13** Examples of air feed chutes

#### Action

169 The type of web-feeding system chosen will greatly influence the risks involved in the process. The following web-feeding methods are listed in order of preference, with the safest first:

- Automatic web-feeding systems which remove the need for any manual intervention.
- Semi-automatic tail-feeding systems with manual tail-feeding using tail-carrying devices or air knives to keep hands away from in-running nips.
  - Feeding using a semi-automatic tail-feeding device into in-running nips should be at the slowest practicable machine speed.
  - Identify the places on the Sheehan rope system where it is considered appropriate to manually tail-feed.
  - Manual tail-feeding – this should only be done by fully trained, experienced operators.
- Hand feeding – advancements in tail-feeding technology have virtually removed the need for hand-feeding. Hand-feeding into machine roll-nips is dangerous and should be eliminated where practical.

170 If for technical reasons it is not possible to install automatic or semi-automatic threading devices, hand-held threading equipment or threading devices with manual adjustment can be provided. These allow manual threading of the web, eg adjustable blast pipes, tail-threading plates and integrated air lances. All devices should be designed and positioned away from danger points when operated.

171 In-running nips can exist on web-feeding systems. On automatic and semi-automatic systems mechanical hazards may also be present. Where in-running nips and mechanical hazards are accessible, guards should be provided to prevent access to the hazard.

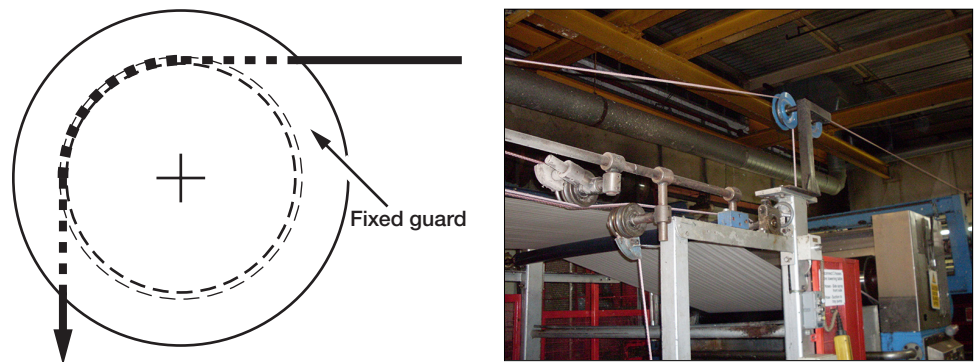

**Figure 14** Web-feeding system and guarding

172 Ropes used in threading systems periodically have to be replaced. Replacing Sheehan ropes should only be carried out under a safe system of work that is strictly enforced. Wherever possible the task should be carried out with the machine stationary. Only if it is absolutely necessary should work be allowed on a moving machine and additional safeguards will need to be in place, such as running the machine at a maximum of crawl speed.

173 Safe access will be required to all pulleys during rope replacement to allow the ropes to be re-fed. Once complete, all guarding should be replaced before the machine is run up to full speed.

174 Ropes that have failed should be replaced before the next web-feeding operation. It is NOT acceptable to manually feed a machine designed to be rope-fed.

175 Webbing up a machine can be one of the most stressful jobs in a mill. Operators feel under perceived pressure to keep production going which increases as misfeeds continue. Accidents at this time are probably more likely than at any other. Also, if it has taken a long time to get the sheet through the machine, there is pressure not to stop it for short-term interventions, such as removing broke. Operators can take chances rather than risk having to go through the feeding process again.

176 If the culture of the mill is perceived to be 'production first', it will be demonstrated in the practices used during webbing-up and in the risks taken to avoid stopping a machine. Mills need to set out their policy in this area. Make it clear in both words and actions that safety is paramount in your organisation and shortcuts are not acceptable. Operators confronted by abnormal situations will be guided not just by instructions but by what they understand are the real risks and by the attitudes of supervisors or managers.

177 Some mills have recognised the pressures from persistent misfeeding and have empowered supervisors to give the crew a break.

# Stock preparation and de-wiring

## De-wiring

178 This section mainly deals with manual de-wiring of bales. For more information and guidance on requirements of machines for de-wiring bales and units that are not hand-held, see BS EN 1034-13.<sup>15</sup>

### Hazards

- Wire whipping when cut and causing severe injuries to face, hands and arms
- Musculoskeletal injuries from repetitive movements during cutting or twisting to remove wire
- Cuts, puncture wounds from wire
- Tripping on loose wire
- Bales falling
- Shearing hazards from wire cutting tool

### Actions

179 Where possible, manual de-wiring should be eliminated by the use of automatic systems such as those covered in BS EN 1034:13.

180 Where this is not reasonably practicable, other measures should be taken to reduce the risks, for example powered mechanical cutters (eg pneumatic, electrical or hydraulic cutters) (and/or mobile plant) can be used.



**Figure 15** An example of a forklift truck with serrated clamp arms to cut bale wire

181 If it is not possible to use automatic systems or other powered means, manual de-wiring should be the final option. The risk assessment of this activity should identify the correct technique for cutting wires to reduce the risk of wire whip and operators should be trained in this technique.

182 De-wiring should be done in an area designated for this task. Untrained and unprotected people can then be kept away from this danger zone. Operators should also wear the correct PPE such as full-face visors with chin guards that prevent the wire whipping underneath, gauntlets (or gloves with additional forearm protection) for cutting wires around bales of waste or pulp. Gloves are not adequate by themselves.

183 Pulling cut wires from under a bale is a manual handling hazard. Where possible, provide devices that lift the bale clear of the conveyor, to remove the risk of back injury. Alternatively, some mills have fitted cleats on the side of the conveyor to wrap the wire around. As the bale proceeds up the conveyor, the wire is then pulled clear.

184 De-wiring bales that are stacked either in a storage area or on a conveyor can cause the stack to become unstable. Bales can then fall, potentially injuring a person. Stacked bales should not be de-wired, they should be removed from the stack prior to the wire being removed.

185 If wires are removed from the bale they should be put in a bin or wire baler. If large amounts of wire have been removed, it is preferable to use mobile plant to transport the large bales around rather than manually handling them. Make sure that the ends of the wire do not stick out of any bin or baler.

### Conveyors feeding pulpers



**Figure 16** An example of a horizontal conveyor feeding a pulp storage tank in the stock prep area using fixed guarding and extended sides

#### Hazards

- People going onto the conveyor
- Crushing and shearing between fixed parts of the conveyor and the load
- Entanglement or drawing-in at nip points
- Loads falling down or off the conveyor
- Slip, trip and fall within the stock preparation area onto the conveyor
- Injury as a result of clearing blockages
- Falling onto the conveyor or getting clothing or footwear snagged, for example on baling wire and being carried into danger
- Falling off the conveyor or into the pulper as a result of the conveyor operating when clearing blockages, removing foreign objects or carrying out maintenance, eg on 'magic eyes' at the top of the conveyor
- Punctures or cuts from bale wire protruding from the conveyor into work or pedestrian areas

#### Actions

##### **General action points**

186 Dangerous moving parts of the conveyor should be guarded. This includes areas on the underside of the equipment that may be accessible, particularly on inclined conveyors. In addition, in-running nip points, eg between the conveyor and rollers should also be guarded.

187 The sides of the conveyor should be high enough to prevent materials being fed to the pulper, falling off onto people. This may mean that side guards are needed on the conveyor. In addition, to prevent materials falling back down the conveyor, keep the carrier bars (flights) on conveyors maintained in good order.

188 There is a potential crushing and shearing hazard where the de-wired bale passes the side guard of the conveyor. If this is a hazard, guards may be designed to reduce the hazard, eg tapering guards.

189 Some conveyors can be reversed to help clear blockages. You should only be able to start the reverse motion under hold-to-run control and the control should be in a place where the operator can see the whole of the conveyor. Make sure that any in-running nips created between the belt and rolls when the conveyor is reversed are guarded.

190 Safe systems of work should be provided not only for normal operation but also for clearing blockages and maintenance of the conveyor. The safe systems of work should also cover isolation procedures.

### **Access onto conveyors**

191 The starting point for thinking about conveyor safety is how to keep people off them. If anyone has to go onto a conveyor frequently or routinely, you need to find out why and tackle the causes. For example, if blockages keep happening you need to change the way the conveyor is fed – some redesign of the conveyor might be the answer, or give the operators better training. If the reason is to remove foreign objects, you should provide arrangements for pre-sorting.

192 Going onto a moving conveyor should not be permitted in any circumstances. If you cannot avoid going onto a conveyor, the conveyor, any associated feed conveyors/mechanisms and the pulper being fed should be isolated, regardless of the length of the job.

**ACCIDENT** – An employee was crushed to death inside a cardboard baling machine while attempting to clear a blockage when paper and cardboard jammed at the top of the machine's conveyor.

The employee who hadn't been formally trained or authorised to use the machine, and was operating it alone, climbed up the conveyor to try to clear it. As he did, he fell into the hopper.

The machine hadn't been isolated or locked off and the employee was killed by the baler's mechanism.

The company were prosecuted by HSE and received a £180 000 fine and ordered to pay £38 000 costs.

193 An additional risk with horizontal conveyors is the risk of people falling on them. If horizontal conveyors feeding pulpers are less than 1.1 m high, they should be provided with a guard at least 1.1 m high along the sides. The guard should be designed so it does not provide a foothold to allow people to climb over it, eg smooth sides, vertical slats etc.

194 Never rely on the locking-in of an emergency stop button to prevent the conveyor being started up when going onto it. Use a full-body harness fixed to a suitable, tested, anchorage point above the working position. The risk assessment

will need to determine whether work positioning, restraint or fall arrest is the most appropriate method. Whatever measures are chosen, they should be sufficient to stop a person reaching the surface of the pulp should they fall into the pulper. If fall arrest systems are provided, you should ensure there is a sufficient drop to allow the 2 m arrestor to deploy along with the height of the person falling. This will be an approximate 4 m drop. All equipment should be regularly checked for damage. A simple safety belt is not considered suitable.

195 If access is needed onto conveyors, consideration should be given to an additional drop-down guard or door to go over the entrance to the pulper. This could be positioned during tasks involving accessing the conveyor. Its purpose would be to provide a safeguard to prevent a person falling into the pulper. Once the task is finished the guard would be removed. A harness would still be required to protect people from falling off or through the conveyor. In addition, a fixed tunnel guard extending from the entrance to the pulper for at least 1 m along the sides of the conveyor can also be used to prevent a person falling off the conveyor. Where a 'goal post type' emergency stopping system is used, or emergency stop buttons are provided along the sides of the horizontal conveyor, the fixed tunnel guarding should extend from the last goal post or emergency stop button to the entry point of the pulper.

196 Clearing blockages at the top of the conveyor should be done from a working platform (with fixed access), not from the conveyor itself.

### **Emergency stops**

197 Emergency stops are provided to stop the conveyor in the event of danger. They are not intended as a means of preventing unexpected start-up while someone is on the conveyor.

198 The system chosen should be easy to operate and accessible by a person who, for example, has fallen onto the conveyor or is trapped as well as by someone seeing a person in danger on the conveyor.

199 There should be at least one emergency stop button close to the feed point of the conveyor, in addition to the emergency stop system on the conveyor itself. Any of the following emergency stop systems may be used. They are listed in order of preference:

- a tripwire fitted along the top edge of both of the conveyor side panels (Figure 17);
- a single trip wire hung centrally up the length of the conveyor with pull cords suspended from the tripwire to make it easy to operate (Figure 18);
- tripwires arranged like 'goalposts' over the conveyor. The first goalpost should be within 2 m at the beginning of the conveyor and within 2 m of the discharge point, and at least every 3 m between these points. They will also need to have suspended pull cords to make them easy to operate (Figure 19);
- push buttons along the top edge of both of the conveyor side panels. The recommended interval between push buttons is 3 m or less.

200 If a tripwire system is used, the tripwire should either have a switch at both ends or have a single switch at one end and tension spring anchors at the other so that the emergency stop system will work if the wire is pulled from any direction, and from any position along it. The system should also stop the machine if the wire breaks.

201 Emergency stop devices should be tested regularly. Self-monitoring emergency stops will still need to be tested regularly to see if they work, as the relays on these systems will not check, for example, that the actuators work.

Physical checks and regular testing are needed to make sure that emergency stop devices are not, for example, clogged up with paper dust.

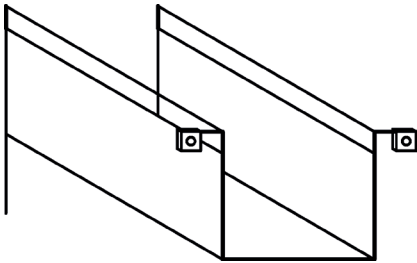

**Figure 17** Example of tripwires along the side configuration pull cords

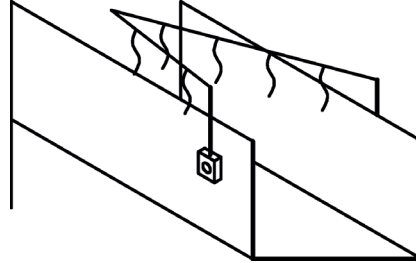

**Figure 18** Example of 'V' configuration pull cord

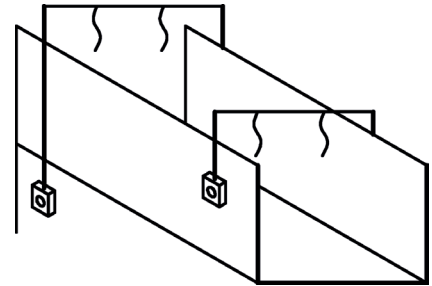

**Figure 19** Example of goalpost configuration pull cords

202 The control system for the emergency stop systems on conveyors feeding pulpers should meet the requirements of BS EN ISO 13849-1.<sup>16</sup>

203 Note that personnel detection systems which, for example, rely on a signal receiver over the conveyor and transmitters which are worn on a belt, are only acceptable as additional safeguards – they should not be used as alternatives to emergency stop devices.

## Pulpers, agitators and stock tanks

204 This section is about the precautions for pulpers, but similar hazards and safeguarding measures are also relevant for agitators and stock tanks.

### Hazards

- Drowning in a loaded pulper – if you fall in, your chances of getting out alive are negligible, even with the rotor stationary
- Drowning if water feeds are turned on while working inside
- Contact with rotors/impellers
- Burns from hot stock splashing from openings
- Entanglement in a motor drive
- Contact with ragger rope guillotine
- Being struck by material falling from the feed conveyor into the pulper
- Falls from height while entering or working in pulper
- Toxic fume or oxygen deficiency while working inside
- Explosion risks from gases (hydrogen sulphide) given off by pulp ignited by hot work
- Falling into an under-machine pulper

### Actions

205 Pulpers have a number of dangerous moving parts that should be safeguarded to prevent a person reaching them. Mechanical hazards include:

- Rotors and impellers – it should not be possible to reach them through the feed opening. If it is possible, additional guarding will be required.
- Drive shafts and motors – any accessible dangerous moving parts should be guarded.
- Ragger rope guillotine – if it is possible to access the guillotine, additional guarding should be provided.

- Side opening pulpers – to prevent access to moving parts, the safety distances in Table 2 and Table 4 of BS EN 13857 shall be applied or additional guarding will be needed.

206 It is possible as the stock is heated and moved that it can splash out through openings. To prevent this, measures such as providing doors or curtaining should be taken. Whatever precautions are taken it is important to ensure that they do not create other risks, eg manual handling of heavy doors or unpropped doors falling under gravity.

207 Some papermaking machines have pulpers underneath them to allow broke to be fed down a chute into them for reusing. If pulpers are provided under machinery, steps will need to be taken to ensure a person cannot fall directly into the pulper or down a chute into the pulper. This could be by using fall-off protection, guarding this area etc.

### ***Accessing pulpers***

208 Access into pulpers can be very hazardous as there are many risks that need to be properly managed. In addition, pulpers (including open-topped ones) are confined spaces as defined in the Confined Spaces Regulations 1997. Therefore, all entry into pulpers will need to be carried out in accordance with the Regulations. For more information on entering confined spaces, including the rescue arrangements that need to be in place see the 'General guidance' section of this publication.

209 Before entering a pulper it is important to ensure that all processes and plant have been stopped and isolated. Any stored energy should be dissipated and the area made safe before a person enters. As well as isolating the pulper it may also be necessary to isolate any feed equipment, eg conveyors, water, chemicals or raw materials. It may also be necessary to purge these systems as a part of the process. A permit-to-work may help in ensuring that all the necessary isolations have taken place and that the area is safe for the operator to enter.

210 A safe means of access should be provided for people working inside the pulper. The safe means of access, and work area if working at height, should be selected in accordance with the Work at Height Regulations 2005. For more information on access, see the 'General guidance' section.

211 An assessment should be carried out to determine what additional controls may be needed to prevent a person being injured when accessing pulpers. This should consider issues such as appropriate equipment for the environment, eg if flammable gases may be present, steps need to be taken to prevent an ignition source being present or a build-up of gases happening.

### ***Preventing falls into pulpers***

212 Both open-top and closed-top pulpers can have openings that a person could fall through. Steps should be taken to prevent this happening. On open- or closed-top pulpers there may be inspection hatches or other openings. Any inspection hatches or openings that have at least one cross sectional dimension greater than 600 mm should have fixed grilles with bars close enough together to prevent a person gaining access.

213 On open-top pulpers the edge of the tank should be at least 1.2 m above standing level. Standing level may be on a platform rather than the floor. The sides of the pulper walls where the standing level is should be smooth and designed to



prevent giving a person a foothold to climb. If the upper edge of the tank is below 1.2 m, an additional safety barrier should be provided.



**Figure 20** Example of fixed grilles on side and top openings of a pulper. Both fixed grilles have been added to prevent whole body access

214 Access openings on closed-top pulpers should have fixed grilles that need a tool to remove them, designed to prevent a person falling through. When providing covers over openings, consideration should be given to manual handling risks. Providing handles to help manoeuvre them or gas struts etc to help lift them can significantly reduce the manual handling risks. In addition, a prop should be provided to help support the cover when it is open.

215 Access doors are sometimes provided at the top of pulpers to allow a person to enter, to do maintenance etc. Often a ladder is used to get to these access doors. These types of access doors should open outwards and a tool should be needed to open the door. In addition, measures shall be in place to ensure the door cannot be opened unless the pulper drive and any other associated feeding equipment is at a standstill, eg isolation, permit-to-work systems, interlocking.

216 Sometimes to help with manual handling risks, tilt tables, chutes or other feed mechanisms are provided at the pulpers feed opening to allow operators to manually add chemicals, powders etc. It is important to ensure that steps are taken to prevent people climbing onto such devices or fall through them.

### **Explosion risks**

217 There have been explosions in paper mills following a build of the explosive gases hydrogen and hydrogen sulphide, created by pulp decomposing. Under normal circumstances when the pulp is being agitated the risks are reduced, as the explosive gases do not build up and are vented. When agitation of the pulp stops and gases build up there is the potential for them to find an ignition source, eg from hot work being carried out in the area causing an explosion in the pulper. Where this has happened the results have been significant. Note, there may be similar risks present in effluent plant, chests and other storage tanks. You should assess your plant to identify where similar problems may exist and take action.

218 To manage the risks, you should:

- carry out a DSEAR risk assessment (Dangerous Substances and Explosive Atmospheres Regulations) (L138)<sup>17</sup> considering the potential risks of both when the pulp is, and is not being agitated;
- consider ventilation to ensure it is sufficient. This may also include general ventilation of the area, not only the pulper;

- clean tanks regularly. Even if there is good agitation of pulp, there can remain undisturbed parts of the tank allowing bacteria to breed;
- consider the necessary steps to take when the pulper is turned off and if hot work is being carried out. This may include:
  - testing the atmosphere before hot work to ensure no flammable gases are present and continue to monitor the atmosphere during work;
  - purging or ventilating gases to ensure flammable gases are dissipated;
  - continuing pulp agitation during hot work if it is proven that agitation is sufficient to remove gases; then
  - where possible, emptying pulpers and thoroughly clean them before work starts;
  - using equipment that is suitable for the zone classification you have designated it.

## Ragger ropes

### Hazards

- Nip between the rope and capstan
- Shearing and cutting as a result of contact with the guillotine
- Injuries as a result of removing an oversized ragger rope
- Puncture or cut wounds from contact with bale wires during removal of ragger attachment
- Manual handling issues from the weight of rope and attachment
- Transporting running ragger (unstable load dynamics)

### Actions

219 The main hazardous machine parts in this area are the intake between the ragger rope and the capstan, and the guillotine. These should be guarded to prevent access. A fence acting as a guard with an interlocked gate for maintenance can be used. The gate should be interlocked to both the movement of the capstan and the pneumatic-guillotine operating system.

220 The ragger rope will need to be maintained and replaced at periodic intervals. This can be a hazardous task and steps should be taken to reduce the risks. If too much contamination is allowed to build up on the ragger rope, this can cause problems when changing it. If it is oversized, the guillotine may not be effective and it can cause problems manually handling it once cut. In addition, if lots of attachments are used on the end of the ragger rope this can make it difficult to manoeuvre. To manage the risks when maintaining or changing ragger ropes you should:

- provide a guillotine big enough for the size of ragger rope and likely levels of contamination;
- put in place a system to monitor contamination levels;
- when putting systems in place to remove ropes, include the manual handling risks of an oversized rope with attachments, eg using mechanical aids;
- provide a hold-to-run control so the capstan can operate at a controlled speed for feeding new ropes;
- put in place systems to deal with an oversized ragger rope;
- put in place systems to deal with detached ragger ropes;
- wear appropriate PPE during the task, ie as a minimum full-face visor, puncture-/cut-proof hand and arm protection.

221 Replacing blades is also a hazardous task that should be carefully planned. When changing blades both the capstan and guillotine should be isolated. Accidents have happened during maintenance because the electrical system has

been isolated but not the pneumatic supply to the guillotine blade which normally operates on a timer. Make sure your isolation procedure is written down, clearly detailed and operators are trained to use it.

## Cleaners



**Figure 21** Bank of plastic vortex cleaners with glass sights



**Figure 22** Single heavy-duty metal vortex cleaner

## Hazards

- Slips/trips/falls
- Explosion
- Pulp splashing in eyes
- Mechanical hazards while clearing blockages

## Actions

222 The area around the hydrocyclone/vortex cleaner unit can be slippery as a result of contamination, eg water, dust. A system should be in place for monitoring levels of contamination and procedures should be in place to remove it as it builds up. This can include regular cleaning regimes, providing spill kits and preventing access until the contamination can be removed.

223 It is important to make sure the structural condition of the cleaner and sight glasses do not deteriorate. Monitoring should be in place to identify any deterioration, eg cracks, holes etc. If any deterioration is identified, action should be taken to replace sections or repair them. Any replacement or remedial work should be carried out with measures in place to protect against hazards, such as fire from welding, mechanical hazards, splashing from water and pulp etc. A permit-to-work system that considers these hazards may help to manage the risk and should identify all necessary isolations and PPE required prior to work starting.

224 It is important to ensure that sight glasses designed for use in this type of system are used. They should be reinforced and laminated and are often designed to collapse inwards instead of leaking. As soon as a crack in the sight glass appears the unit should be shut down and the sight glass replaced.

225 Cleaners will block with contaminants from time to time. Safe systems of work should be in place to ensure that unblocking the cleaner is carried out safely. The system of work should include:

- how access will be gained into the cleaner;
- tools that may be required;
- procedures to remove the blockage;
- isolations needed;
- safe work at height procedures;
- dust exposure;
- heat stress.

## Refining

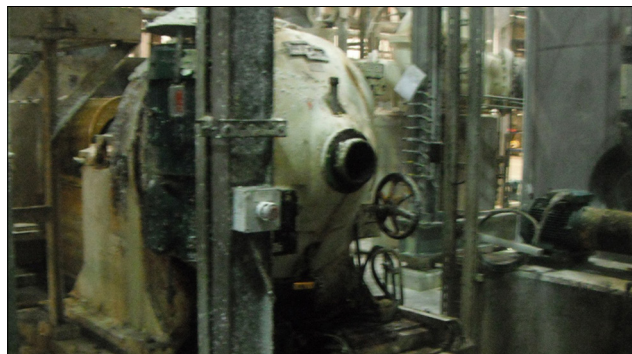

**Figure 23** A typical example of a refiner

## Hazards

- Mechanical hazards from moving parts inside the refiner and motors
- Burns from hot surfaces and stock
- Slips and trips
- Struck by falling objects during maintenance
- Falling from height while taking samples or carrying out maintenance
- Cuts and abrasions from handling contaminated or damaged refiner plates

## Actions

226 There are a number of moving parts on the refining unit that could be dangerous. These include the refiner tools, transmission shafts and motors. Access should be prevented to dangerous moving parts, preferably by fixed guards. If there are access panels to allow for maintenance etc, these should either be removable with a special tool or if frequent access is required, interlocked.

227 There can be a number of areas around the refiner where hot surfaces may be a risk. Mills should identify areas where this may be a hazard and decide on the action needed depending on where the surface is and the temperature it may reach, eg provide guarding, insulation, warning signs.

228 The area around refiners can be slippery as a result of contamination. A system should be in place for monitoring this and where there is contamination procedures should be in place to ensure this is dealt with appropriately. This can include regular cleaning, providing spill kits and preventing access until the contamination is removed. Other measures may also be used, eg where there is an overflow pipe from the refiner, consideration should be given to divert this to a drain if additional hazards are not created (see Figure 24), such as trip hazards.

229 Access will be needed into the refiner for cleaning, inspection, maintenance and sampling. Safe systems of work should be agreed and followed before access is allowed. Safe systems of work should include:

- isolations that are necessary;
- steps to dissipate stored energy;
- measures for preventing hot stock discharging unexpectedly, eg running a flush cycle of the refiner;
- cool down periods for hot surfaces and stock;
- propping of mechanical parts that may move under their own force;
- when and how refiner plates should be removed, eg during maintenance, by crane or other lifting device;
- tools and specialist tools that may be needed to do the task;
- access equipment for working at height;
- exclusions of access to the area needed, eg if work is going on overhead or if lifting operations are happening;
- any PPE needed to carry out the tasks.

230 Before removing the refiner plate, this process should be planned. It may be necessary to use specialist bespoke lifting equipment. If it is necessary to handle the plate by hand, PPE, eg gloves and gauntlets are suggested as there may be burrs from plate damage or contaminants that may cause injury. Keeping all the tools and equipment needed in one place may be a good way of ensuring it is used (see Figure 25).



**Figure 24** Contamination around the refiner being discharged into drains, cleaning will also be needed



**Figure 25** A storage box for tools and equipment

# Papermaking machine

## Head box

### Hazards

- Asphyxiation or drowning as a result of entering a confined space
- Crushing, entanglement and shearing hazards on dangerous moving parts such as drive shafts, agitators, baffle rolls, head box, suction boxes and other adjustable equipment
- Being struck by a falling head box lid
- Falls from height during interventions, particularly when adjusting 'the slice'
- Slips and trips

### Actions

231 There is a risk of asphyxiation due to chemical fumes being released during cleaning, or drowning as a result of water entering the head box. Therefore, head boxes are confined spaces as defined in the Confined Spaces Regulations 1997. More information on precautions that should be in place when entering confined spaces can be found in the 'General guidance' section.

232 There may be access to dangerous parts of machinery in the head box, eg agitators, baffle rolls, breast roll, evener rolls and rotating shafts. Any dangerous parts of machinery should be guarded to prevent access to them.

233 Operators may need to carry out manual adjustments while the machine is in use. If it is not possible to make adjustments when the machine is stopped, mills should ensure that operators cannot come into contact with dangerous moving machinery. It may be possible to extend controls and levers outside of guarded areas so adjustments can be made safely. Where this is not possible, an access point may be provided in the guard. The access point should comply with the reach distances to hazardous moving parts as specified in BS EN ISO 13857.

234 The area around the head box can be slippery. Consideration should be given to the flooring surface in and around the head box area to prevent people slipping. See 'Slips, trips and falls' in the 'General guidance' section.

235 Cleaning and maintenance tasks will need to be carried out in the head box area. You may find permit-to-work systems will help ensure tasks are carried out safely. To manage the risks of these types of tasks, you should:

- put in place safe systems of work for cleaning and maintenance activities;
- ensure all isolations are completed prior to work starting;
- provide the necessary training;
- specify access equipment for work at height (see 'Safe access to plant' section for more information);
- provide a means to secure the head box lid open, eg mechanical supports etc.

## The wire

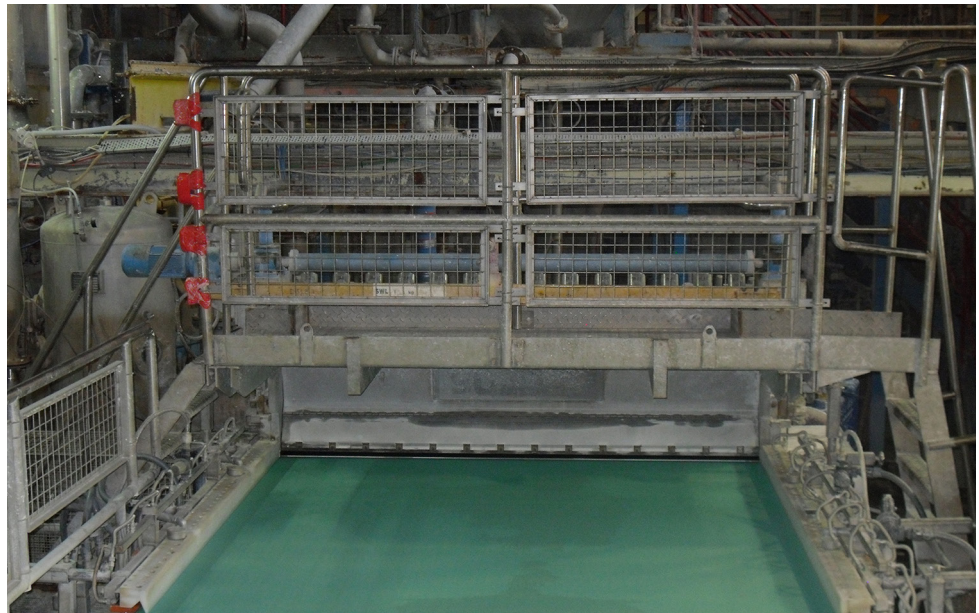

**Figure 26** Protective structures and railings used to prevent access to the wire

### Hazards

- In-running nips between wires on multi-wire machines and between wire and rolls
- Entanglement with drive and couplings to the shake mechanism and the wire drive rolls
- Exposure to high-pressure showers
- Exposure to chemicals used for cleaning wires
- Cutting hazard from edge of wire
- Falling from platform and cross-machine walkways
- Drowning, crushing or impact injuries as a result of falling into the under-machine pit, chest or couching vessels
- Crushing, shearing and entanglement hazards on rotary round wire cylinders or dandy rolls created by the spokes and other machines parts

### Actions

236 There are many in-running nip points on and around the wire, eg between press roll and head box; dandy roll and the wire or foil; fixed points and the wire; and wire guide or wire tension rolls and fourdrinier wire. All in-running nip points should be guarded. See the 'Safeguarding machinery' section for more information on guarding nip points.

237 The edge of the wire should be protected to prevent cutting hazards as the wire moves. This can be done by providing protective structures along the edge of the machine in accordance with BS EN 13857, Tables 2 and 4.

238 Some papermaking machines have more than one wire. A nip point may therefore exist at the point the wires meet. Multi-wire machines should therefore have guarding on nip points where the wires meet.

239 Drives to the wire shake, couch or other rolls must be completely enclosed with fixed guarding.



**Figure 27** Fixed guards to prevent access to moving rolls underneath the wire

240 Where rotary round cylinders or dandy rolls have spokes, the end will need guarding to prevent access into the shear point as they rotate past machinery parts.

241 If there is a risk of falling into the under-machine pit, basement, chest or couching vessel under the wire, fall-off protection should be provided as follows:

- at ground floor level – a fixed guard that prevents access;
- on passages and walkways across the machine – a minimum of railings at least 1.1 m high with intermediate rails and kick plates (see ‘Safe access to plant’ in the ‘General guidance’ section);
- where dangerous parts could be reached by someone standing on the railings – fencing which does not permit a foothold.

242 The design of any guard should allow cleaning with hoses but not allow people to reach dangerous parts.

243 Where access to or across the wire is needed, suitable platforms should be provided. Platforms should have handrails, intermediate rails and kick plates on both sides. (see ‘Safe access to plant’ in the ‘General guidance’ section).

### ***Changing a wire***

244 Changing a wire is similar to changing a fabric and a lot of the safety precautions apply to both tasks. The section of this guidance covering ‘Fabric changing’ should be referred to for further advice.

245 Additional hazards that are not present when changing a fabric should be considered. Issues such as ‘endless wires’ that can cause access and manual handling problems should be assessed and controls put in place. Access in and around guards should also be assessed. It may be possible to design guards to allow easy access to change the wire and provide good visibility for the task.

246 When changing the wire there can be significant risks relating to work at height, particularly as the task involves manually handling the large wire at height. Therefore, suitable and safe means of access and working platforms should be provided. As the wire will periodically need to be changed, it is preferable to provide a permanent means of access.

### ***Wire cleaning***

247 Where possible, wire cleaning should be done by an automatic system.



248 Where it is not possible to use an automatic wire cleaning system, a safe system of work will need to be agreed. This should include:

- isolations and permits-to-work required before starting work;
- restricting the area to those involved in the operation using suitable barriers and warning signs;
- safe means of access to areas to be cleaned;
- instructions for safe cleaning methods that reduce potential exposure to chemicals and reduce the likelihood of slips and trips;
- if it is not possible to undertake cleaning tasks with the machine stopped, the wire should only be moved at crawl speed under a safe system of work;
- appropriate personal protective clothing – usually this will be a full chemical suit for those involved;
- adequate training for all those involved;
- a robust system for dealing with chemical spills.

249 Where needle showers are used for wire cleaning, they should have:

- fixed impervious guards to prevent access to high-pressure needle showers, including the underside of the machine;
- safe systems of work agreed for all maintenance and cleaning tasks. The safe system of work should consider all necessary isolations, training required and any permits that need issuing.

## **Transfer point to press section**

### Hazards

- In-running nips between fixed and/or moving parts, eg couch and carrying roll
- Crush and trapping injuries during manual transfer of the web by hand
- Falling into underwire (couch) pit

### Actions

250 Transfer of the web from the couch to the first felt roll should be done wherever practicable by mechanical means. Mechanical means can include, eg an air blower or a pick-up roll (see the 'Tail and web threading' section).

251 All in-running nips at the press transfer point should be guarded to prevent access to nip points. For more information, see 'Guarding in-running nips' in the 'General guidance' section. The paper-carrying roll and couch roll should be at least 120 mm apart and this gap should be maintained, if not, fit a guard to prevent access to the nip.

252 Where it is possible for a person to fall into the underwire (couch) pit, fall-off protection should be provided, eg fixed fencing.

## Press section



**Figure 28** Press section enclosed with fixed guarding

### Hazards

- In-running nips between fixed and/or moving parts, eg between felt roll and stretch and bow rolls
- In-running nip between the raised doctor blade and roll
- Wrapping points, eg of felts on press and guide and stretch rolls etc
- Falling onto felt and being carried into press rolls
- Entanglement on protrusions at the end of rolls, eg nuts or cap screws
- Injuries during cleaning, maintaining and changing press rolls and felts
- Injuries from high pressure jets on needle showers used for felt cleaning
- Falling from cross-machine walkways and platforms

### Actions

253 All in-running nips should be guarded both to the front and back of the machine. The guard should prevent anyone reaching into the nip from either above or below the felt, eg by guarding the whole width of the in-running nip. If whole body access is possible, guards should prevent a person climbing in. For more information, see 'Guarding in-running nips' in the 'General guidance' section.

254 To prevent entanglement, provide a guard with a smooth surface over any parts sticking out from the ends of rolls.

255 All wrapping points, eg on press, guide and stretch rollers and felt dryers should be guarded. If such points can be reached from under the machine, the guard should extend across the whole accessible width.

256 A hold-to-run control should be provided where guards do not protect crushing points created by press rolls moving together. The operator of the hold-to-run control should be able to see the danger zone. The design of some machines mean that as the rolls open up there is a crushing hazard present. On machines where this is a hazard, a hold-to-run control should be provided for the opening movement.

257 Some machines have roll nips that open automatically as a result of a web break. If the distance between the two open rolls, or an open roll and a fixed part of the machine is less than 120 mm, guards in this area should be designed to protect the open roll nips. If a nip bar is provided to protect the nip point when roll nips open automatically as a result of a web break, there should also be a gap between the fixed nip bar and open rolls no greater than 8 mm.

258 Provide working platforms across the machine to make cleaning, maintenance and changing of doctor blades easier. The platform design should prevent people falling onto the felt and being carried to a hazard, eg the press rolls.

259 Fixed impervious guards should be provided to prevent access to high-pressure needle showers, including the underside of the machine.

260 Provide a written safe system of work for changing press rolls, maintenance and cleaning tasks. This should cover the procedures for isolation, training required, safe lifting, access arrangements, replacement of guards and cleaning (particularly with caustic washes).

## **Dryer section**

### Hazards

- In-running nips between fixed and/or moving parts, eg cylinders and felts/felt carrying rolls, air blowers, machine frame and Sheehan ropes and pulleys
- In-running nip between raised doctor blade and roll
- Wrapping points, eg on guide rolls, sheet supports etc
- Entanglement on protrusions at the end of cylinders, eg nuts or cap screws
- Burns from contact with hot surfaces
- Falling into machine or under-machine pulper from cross-machine passageways
- Heat stress working inside machine hoods
- Injuries caused by the failure of lifting mechanism for machine hood
- Crushing injuries from the closing machine hood
- Lacerations from doctor blades
- Confined space inside cylinders

### Actions

261 There are a number of dangerous moving parts in the dryer section that should be guarded to prevent access. Areas that need considering and guarding include:

- all in-running nips to the front and back of the machine;
- in-running nips accessible from cross-machine passageways;
- where whole-body access to dangerous moving parts is possible;
- where upper or lower limbs can access dangerous moving parts;
- parts sticking out from the ends of rolls.

262 The selection of guards used should be appropriate to the area. Where frequent access or access for removal of broke or cleaning is required, interlocking moveable guards with a guard locking device that meets BS EN ISO 14119<sup>18</sup> and is interlocked with the cylinder drive should be provided. Interlocking movable guards should be provided at each point where access is needed. Any guarding should be carefully designed to allow for broke removal and for cleaning and changing doctor blades.

263 Access is sometimes needed into the drying cylinders for maintenance, inspection and testing. Drying cylinders are confined spaces falling under the definition of the Confined Spaces Regulations 1997. Therefore the requirements of these Regulations will need to be fulfilled before a person enters the drying cylinder. For more information on safe work in confined spaces including training, rescue plans etc, see the 'Working in confined spaces' section.

264 If there is a risk of falling into the under-machine pit or basement under the drying section, fall-off protection should be provided as follows:

- at ground floor level – eg a fixed guard that prevents access;
- on passages and walkways across the machine – a minimum of railings at least 1.1 m high with intermediate rails and kick plates (see ‘Safe access to plant’ in the ‘General guidance’ section);
- where dangerous parts could be reached by someone standing on the railings – provide fencing which does not permit a foothold.

265 The design of any guard should allow cleaning with hoses but not allow people to reach dangerous parts.

266 If gaps are left below the guard/fall-off protection for cleaning or removing broke, this should be as narrow as possible and not exceed 300 mm.

267 Where access is needed to clean or change doctor blades, suitable platforms should be provided. Platforms should have handrails, intermediate rails and kick plates on both sides (see ‘Safe access to plant’ in the ‘General guidance’ section).

### ***Pit access***

268 Where a machine is sitting over a pit, access to the pit is usually by means of steps or ladders located within the area of the machine. Within the pit there may be access to dangerous moving parts. Where access to dangerous moving parts is possible, localised guarding should be provided. Where this is impractical, an interlock gate should be provided.

269 If there is no access to dangerous moving parts or other hazards, access to the area should still be controlled. Depending on the level of risk, it may be sufficient to provide a locked gate where the key is under the control of a responsible person and only released under a strict isolation procedure.

### ***Machine hood***

270 Drying sections usually have machine hoods designed to improve drying efficiency, reduce noise and heat exposure in the workplace. The hood doors may also be a guard for this area of the machine. If the hood doors are used to provide guarding they should be interlocked. They should be interlocked to any machinery or equipment in this area that is a hazard to prevent access to moving parts. Guard locking may be required based on the access to moving parts and run-down time of machinery in this area.



**Figure 29** Interlocked hood doors can be used to prevent access to the drying cylinders

271 Access doors should be provided at each end of the hood. No point under the hood should be more than 25 m from a door so additional doors may need to be provided.

272 People should not be allowed under the hood with the lifting panels down. However, where access is needed at regular intervals to go to a set location with the panels down, the distance between that location and the nearest door should be no more than 15 m.

273 Where sliding doors are used as access doors you should ensure that they cannot be pulled or fall out during lifting, lowering or while the hood is raised. Handles should be provided both on the inside and outside of these doors.

274 Failure of the lifting mechanism for the machine hood should not allow the hood to fall under gravity. Devices should be provided which limit the fall.

275 An audible pre-start warning should be given before the hood is lowered. If there are crushing hazards during the lowering of the hood lifting gates safeguards should be in place to prevent a person being injured. This may be done by electro-sensitive devices that monitor the danger zone and prevent the hood closing or by providing a trip bar along the edge of the closing hood.

276 Any trapping points between the hood and any machine roll or machine frame should be eliminated by design, eg by maintaining a gap of at least 500 mm.

277 The heating system used should be interlocked to the process. If it is not and the heating system continues to operate when the process stops, the consequences can be extreme. To reflect this, the control system for the interlocking system should be to at least Category 3 and PL d of EN ISO 13849-1. (See 'Appendix 1' for more information.)

## **Sizing presses and coating units**

### **Hazards**

- In-running nips on applicator rolls, counter rolls, guide rolls, nozzle bodies, ink ducts, scrapers and doctor blades
- Crushing, shearing and cutting hazards on swivel doctor blades, blades and fountains
- Entanglement and drawing-in during inspection and cleaning
- Entanglement on protrusions at the end of rolls, eg nuts or cap screws

### **Actions**

278 All in-running nips should be guarded both to the front and back of the machine. The guard should prevent anyone reaching into the nip from above, below or the sides. Fixed nip bars are commonly used as interlocked trip nip bars can impede feeding up so are not usually suitable. If fixed nip bars are impracticable, a solution may be to provide interlocked gates with guard locking at the cross-machine walkway to ensure that operators can only get access when the machine is stopped.

279 Other dangerous moving parts in this area should also be guarded.

### **Doctor/coating blades**

280 Removing doctor and coating blades can be a hazardous activity. Proprietary devices should be used for removing them. In addition, suitable gauntlets should be provided and worn to prevent cuts. Once the blade has been removed from the machine the edge should be covered straight away and the whole blade placed in a storage box. Blades should not be left on walkways.

281 The following risk reduction measures should be considered when changing, cleaning and transporting blades:

- use bespoke handling equipment to manoeuvre blades both into and out of position;
- where changing blades cannot be carried out from floor level, use platforms or machine walkways to change the blades;
- provide deposit boxes close to removal for placing used blades;
- once removed, blades should be disposed of immediately, eg use a guillotine to chop it up;
- wear appropriate PPE, eg face protection, gauntlets, gloves.

### **Yankee cylinders and through air dryers**

#### Hazards

- In-running nips or wrapping points between the Yankee cylinder and other cylinders, on steam heads, suction press rolls, through air dryer (TAD), wire cylinder and guide rolls, TAD cylinder and drying screen, drying screen and guide and adjustment rolls
- Confined space entry inside cylinders
- Drawing in from snagging hazards, eg bolts on Yankee cylinders
- Burns from contact with cylinders and steam
- Falling into the machine or from cross-machine passageways
- Falling into the under-machine pit, chests or couching vessels
- Lacerations from doctor blades
- Falls from height while accessing the Yankee cylinder
- Failure of the cylinder

#### Actions

282 All in-running nips between contra-rotating rolls (eg between cylinders and press rolls) or between rolls and fixed machinery parts should be guarded. Guarding measures to protect in-running nips can be found in the 'General guidance' section.

283 When identifying where guards are needed for nip points consideration should be given to accessible nips around the whole machine, including where nips can be reached from cross-machine passageways. Any guards implemented need to be designed to allow for cleaning and changing doctor blades.

284 Contact with rotating bolts on Yankee and TAD cylinders should be prevented by design, fixed guard or by safety distance.

285 Yankee cylinders are confined spaces falling under the definition of the Confined Spaces Regulations 1997. Therefore the requirements of these Regulations will need to be fulfilled before a person enters them. For more information on safe work in confined spaces, including training, rescue plans etc, see the 'Working in confined spaces' section.

286 Additional considerations for working inside Yankee cylinders include measures to prevent the cylinder turning while someone is inside and identifying if there is a need to isolate steam/condensate return lines to prevent this flowing back into the cylinder while someone is inside.

287 The cylinder may fail for a number of reasons as follows:

- 'crevice corrosion cracking' which opens the joint between the head and shell;
- cracking of the shell due to differential temperature or pressure, eg during heating up and cooling down;
- continual distortion of the shell due to over-pressure by the press rolls;
- over-pressurisation by steam;
- thinning of the shell, due mainly to frequent regrinding of surface, so that the cylinder no longer meets the design parameters for temperature and/or pressure.

288 To prevent cylinder failure, steps should be taken to reduce the risk. Steps include:

- Check routinely for steam leaks – a mirror on an extended handle can be used. Fix leaks as soon as possible to prevent steam cutting into the head/shell joint and setting up localised stresses.
- Set pressure-relief valves on the steam system with an adequate safety margin (consult with the manufacturer to determine this). They should also be overhauled and recalibrated at least annually.
- To prevent possible distortion of the cylinder, monitor the loading on the Yankee cylinder applied by the pressure rolls – load cells which give an ongoing measure can be used. You should be aware that the likely introduction of shoe presses may increase pressures on the Yankee cylinder and therefore increase distortion.
- Make sure that the systems of work for starting up from cold and for cooling down a Yankee cylinder are written down and operators are trained in them, to prevent temperature differentials causing cracking.
- Make sure that all operators are aware that cold water sprayed onto a hot cylinder can lead to catastrophic failure due to thermal shock.
- A package of measures should be put in place to ensure the safety of working with Yankee cylinders as they are pressure vessels. Maintenance, training and inspection programmes should be formulated and implemented.

289 If there is a risk of falling into the under-machine pit, basement, chest or couching vessel around the Yankee cylinder area, fall-off protection should be provided as follows:

- at ground floor level, eg a fixed guard that prevents access;
- on passages and walkways across the machine – a minimum of railings at least 1.1 m high with intermediate rails and kick plates (see 'Safe access to plant' in the 'General guidance' section).
- where dangerous parts could be reached by someone standing on the railings – provide fencing which does not permit a foothold.

290 The design of any guard should allow cleaning with hoses but not allow people to reach dangerous parts.

### ***Inspection and testing***

291 Yankee cylinders are pressure vessels and therefore fall under the Pressure Systems Safety Regulations 2000.<sup>19</sup> Statutory examinations should be carried out in accordance with the Regulations.

292 In addition, the integrity of the head bolts should be checked using non-destructive testing (NDT). Also, a 'head-tilt test' to detect crevice corrosion cracking should be carried out by a competent person at appropriate intervals.

## Calenders

### ***On-line calenders***

#### Hazards

- In-running nips between rolls
- Open nips at lifted rolls
- Trapping points as the roll moves up and down
- Entanglement in drive shafts
- Crushing hazard as a result of rolls descending due to a pressure loss in hydraulic lines, eg during maintenance and cleaning
- Cuts from doctor blades
- Burns from hot surfaces
- Static discharges
- Falling off walkways and passageways into the calender or to the floor
- Falling down under-floor openings

#### Actions

293 All in-running nips should be guarded where accessible. The guard should prevent anyone reaching to the nip from above, below or the sides. Any guarding should be carefully designed to allow for broke removal and for cleaning and changing doctor blades. If the machine has a reverse gear you should also consider in-running nips created when running in reverse and guard them.

294 Where rolls are lifted during breaks, beware of additional hazards that may be created, eg new nip points, crushing points. If additional hazards are present, guards will need to put in place. In addition, guarding should be provided on the mechanism that moves the rolls up and down.

295 If machine platforms cross the width of the calender, suitable guarding compliant with BS EN 13857 should be used to ensure that no part of the body can reach the in-running nips. (See the 'General guidance' section for more information on safeguarding in-running nips.)

296 If under-floor openings for feeding broke into are provided, steps should be taken to prevent a person falling in and from reaching any dangerous moving parts.

297 Whatever combination of guarding is chosen in this area it should be designed to provide protection during all operations, eg when the rolls are lifted during a web break or when they are down for normal operation. As the rolls are lifted or lowered, eg during a break, if guarding is not designed correctly hazardous parts of the machine may be left unguarded and people may be exposed to mechanical hazards.

298 Nip bars, where fitted, should be regularly checked to avoid excessive deflection across the width of the machine and to ensure vibration has not loosened the securing bolts.

299 Accessible drive shafts should be guarded to prevent a person becoming entangled in it.



300 A build-up of static electricity on calenders may be an issue. To prevent this, earthing and discharge systems should be provided and maintained.

301 To reduce the risks of feeding calenders, tail-feeding systems should be installed. More information can be found in the 'Tail- and web-threading' section.

302 Periodically, doctor blades will need changing on on-line calenders. See the 'Doctor/coating blades' section for more information on how to do this safely.

303 Cleaning and maintenance will need to be carried out at regular intervals on on-line calenders. The following measures will help reduce the risks of these tasks:

- Where possible, provide automatic cleaning systems to clean the rolls.
- Agree safe systems of work, whether using automatic or manual cleaning systems.
- The machine should be stopped when manually cleaning rolls.
- When the rolls need to be moving during cleaning, they should only be operating at crawl speed. A tool that allows operators to clean from outside the guard should be provided.
- A device, eg a chock should be provided to prevent rolls descending while cleaning.
- Emergency stops should be easily reachable from places where cleaning will take place.

### ***Off-line calenders***

#### Hazards

304 The following are in addition to those identified for on-line calenders:

- Entanglement in in-running nips between unreeling and reeling reels
- Trapping underneath the descending travelling working platform
- Working beneath suspended loads

#### Actions

305 The following are in addition to those identified for on-line calenders:

- Guarding or safety measures should be provided to prevent access to entanglement risks in both the unreeling and reeling areas
- On wide machines, nip bars may become impractical due to excessive deflection. If this is the case, enclosing guards should be provided to prevent access to dangerous parts.
- Travelling work platforms should be properly installed, maintained and examined in accordance with the requirements of the Lifting Operations and Lifting Equipment Regulations 1998. All travelling work platforms should also be fitted with:
  - interlocked gates – so that they cannot be moved unless the gates are shut;
  - a trip device on the underside that, if activated, brings the platform to a halt;
  - overrun protection at both ends of travel;
  - controls on the platform;
  - a marked safe working load that should not be exceeded.
- Mills should also refer to 'Safe access to plant' in the 'General guidance' section.

## Reel-ups

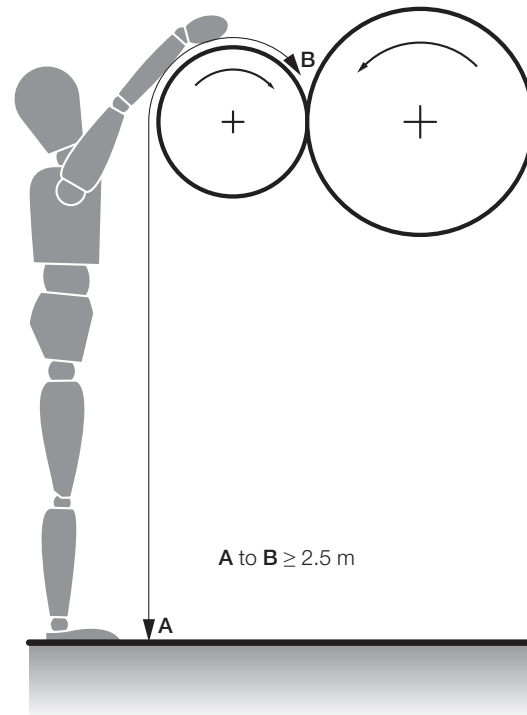

**Figure 30** Measuring the height of a nip at a reel-up

### Hazards

- In-running nips, eg on winding/reel-up units, between web and reel; reel and floor; reel and machine parts; and shell and reel, while manually feeding the web
- Crushing points between rolls and rolls and fixed parts, eg between the rider roll and the paper reel and between the sensor drum and the paper reel
- Entanglement with primary/secondary arms
- Contact with the rotating finished reel
- Impact injury as the reel is ejected
- On reel-ups with storage for reels, crushing between ejected reel and other reels
- Falling into under-machine pulper

### Actions

306 The reel-up area and the process of reel changes are hazardous. A combination of measures is needed to safeguard this area and to ensure people are not injured during changes. The combination of measures and agreed safe systems of work should be done as the result of a risk assessment.

307 In-running nips on winding units that are accessible should be guarded. In-running nips can be found, for example, between the centre drum and paper reel or spreader roll and between the paper reel and rider roll.

308 The in-running nip between the drum and the reel shell throughout the range of movement of the shell should be out of the operator's reach. This requirement is met if the distance measured from the in-feed over the newly transferred shell (ie in its lowest position) and across any spacer, and vertically down to the floor or standing level is at least 2.7 m (see Figure 30). If this distance cannot be met, additional safeguards are required to prevent anyone reaching the nip point, eg fixed guarding, movable guards and Active Opto-Protective Devices (AOPDs).

309 If the nip point can be reached from raised platforms or at the side of the machine from the floor, provide fixed fencing at the sides of the reeler. The height of the guard, its distance away from the nip and how far it must extend either side of the nip can be worked out from the relevant tables in BS EN ISO 13857.

310 If there are crushing or shearing hazards between the arms and fixed machinery in the secondary arms area, access should be prevented. This could be done for example by fixed enclosing guards on individual moving parts, fixed guarding or movable interlocking guards to the sides of the machine.

311 Access to the moving parts of the drive to the primary arms, the tram rails and any other hazardous moving parts should be prevented. This could be done for example by fixed enclosing guards on individual moving parts, fixed guarding or movable interlocking guards to the sides of the machine.

312 There are a number of moving parts in the reel-up area that are crushing hazards and should be guarded. The level and type of guarding chosen should reflect the level of risk present. Crushing hazards can exist:

- between the automatically controlled sensor drum and paper reel (protective devices with approach reaction may be needed in this area);
- as a result of lowering the rider roll onto the paper reel.

313 Devices should be provided to prevent hazards from the rider roll lifting mechanism failing, eg non-return valves on the lifting jacks combined with automatic support devices for the raised rider roll.

314 When reel shells are being inserted into frame supports it is possible that they do not 'engage' properly, causing problems either with their operation or causing the reel shell to be ejected unintentionally. In addition, if reel shells or frames are lifted before the support covers are opened or the gear disengaged, this can cause significant hazards. Measures should be in place to reduce the risks from reels/ frames being ejected, not engaging properly and from being removed before being released. Measures can include:

- providing an inclined support so the reel shell or frame automatically moves into the support;
- providing interlocked support covers;
- providing support walls;
- providing deflector bars or plates to prevent the crane hook being secured until covers are open and gear disengaged;
- interlocks to prevent lifting movement until covers are open and gear disengaged.

315 Where the ends of shells are shaped to fit into the re-reeler brake couplings, the rotating shaft ends should be guarded.

316 A braking system should be fitted into the tram rails to halt the rotation of ejected reels.

317 Automatic reel-loading systems can have additional mechanical hazards that need guarding. Perimeter fencing with interlocked gates or other safety devices can be used to protect automatic reel-loading systems.

318 On reel-ups with storage facilities for full reels, there is a risk of trapping between two reels, particularly between a stationary reel and a moving reel which has been ejected from the reel-up. To avoid this hazard, a minimum gap of 500 mm should be maintained between two full reels on the rail. This can be

achieved by holding the reels at individual brake stations, with the gap between stations designed to accommodate two maximum diameter reels, plus 500 mm. If the storage rail is 2.1–2.5 m above the floor, the distance between the reels should be a minimum of 300 mm. A safety distance of 500 mm minimum from floor level to the lowest point of the reel on the rail should be maintained.

319 If there is a risk of falling into the under-machine pulper, fall-off protection should be provided as follows:

- at ground floor level – a fixed guard that prevents access;
- on passages and walkways across the machine – a minimum of railings at least 1.1 m high with intermediate rails and kick plates (see ‘Safe access to plant’ in the ‘General guidance’ section);
- where dangerous parts could be reached by someone standing on the railings – fencing which does not permit a foothold;
- if people can reach up and make contact with dangerous machinery, provide additional local guarding on the dangerous part;
- any gaps to allow access for pushing broke into the under-machine pulper should be as narrow as possible, but should not exceed 300 mm.

# Appendix Updated information on design and implementation of safety-related electrical control systems

**1 The information in this Appendix supersedes and updates the guidance on safety-related control systems for papermaking machines published in paragraphs 31–47 of the first edition (2001) of Part 6, Making paper safely: Managing safety in the papermaking process.**

**2 This Appendix provides a technical framework that can be used by mill engineers for the design and implementation of safety-related electrical control systems that are used to carry out safety functions at papermaking machines. This is drawn from published standards and other sources that take a systematic approach towards the specification, design, installation and operation of safety-related electrical control systems to achieve safety performance requirements derived from a risk assessment.**

## What is a control system?

3 A control system responds to input signals from the machine, or from the operator, and generates output signals, which make the machine operate in a desired manner. So if, for example, an operator presses a start button, the control system may respond by closing a contactor and energising a motor.

4 Control systems can be implemented in a range of technologies, but this guidance is mostly concerned with electro-technical systems employing electrical, electronic and programmable electronic technologies.

## What is a safety-related control system?

5 A control system in a papermaking machine should be regarded as being safety-related if it contributes to reducing any risk to an acceptable level or if it is required to function correctly to maintain or achieve safety. The functions carried out by a safety-related control system are termed 'safety functions'. Safety-related control systems should be designed and configured to:

- be reliable enough (bearing in mind the consequences of any failure); and
- perform the necessary functions to achieve or maintain a safe state or mitigate the consequences of a hazard.

6 The design must take full account of the level of risk reduction that the system is required to achieve. This is because, in principle, the required level of risk reduction will have a significant influence on the design techniques needed for reliability and tolerance to faults.

## General principles of safety-related control system design

7 The design characteristics for reliability and fault tolerance of a safety-related control system must stem from the basic risk assessment carried out on the machine. This assessment will identify aspects of the machine's operation that create risks that may need to be reduced to an acceptable level.

8 Designers may employ a range of techniques to reduce the level of risk, many of which will not involve the use of safety-related control systems. For example, the use of fixed guards will prevent access to dangerous parts, and the provision of platforms and walkways will reduce the risk of falls from height.

9 However, in many cases risks cannot be reduced to acceptable levels without incorporating safety-related control systems. In this case, the designer needs to understand and assess the contribution that these systems make to the reduction of risk, and the consequences for system reliability and fault tolerance. The more critical the role played by the safety-related control system, the more reliable and resistant to faults it must be. This property is known as the safety integrity of the system, which is a measure of how well the safety-related control system will perform the required safety function(s) under all stated conditions within a stated period of time. An adequate level of safety integrity may be achieved by a combination of:

- the reliability of the hardware and software; and
- the way the parts are combined in the design of the control system; and
- the use of diagnostic and testing techniques.

10 The designer should identify all the safety functions to be performed by the safety-related control systems and specify their required safety integrity. This is known as the safety requirements specification and is of fundamental importance for achieving safety by design. The overall process is illustrated in Figure 31.

11 In designing a safety-related control system to achieve an appropriate level of safety integrity that is commensurate with its contribution to risk reduction at the machine, consider the following:

- the reliability of the equipment that comprises the safety-related control system;
- the use of techniques such as redundancy and/or automatic diagnostics;
- how to prevent, as far as possible, faults in design and manufacture of hardware and software (eg software 'bugs' or faulty wiring);
- how to incorporate design features which may help the control system to recover from faults during operation (eg programme sequence monitoring);
- the behaviour of the safety-related control system under fault conditions (failure modes) and the desired reaction to these fault conditions;
- how to test the safety-related system(s) initially to show, as far as possible, that there are no design, manufacturing or installation faults before the machine is put into operation;
- how to design periodic test and inspection procedures for the safety-related system(s) that can be applied periodically throughout the lifetime of the machine, to show that no part (including both hardware and software) has changed or deteriorated beyond reasonable limits.

12 These issues must be taken into account for all parts of the safety-related control system including hardware, software and the way that parts are combined during integration. Remember that the safety-related control system comprises everything necessary to carry out the required safety function (eg sensors, control logic and brakes).

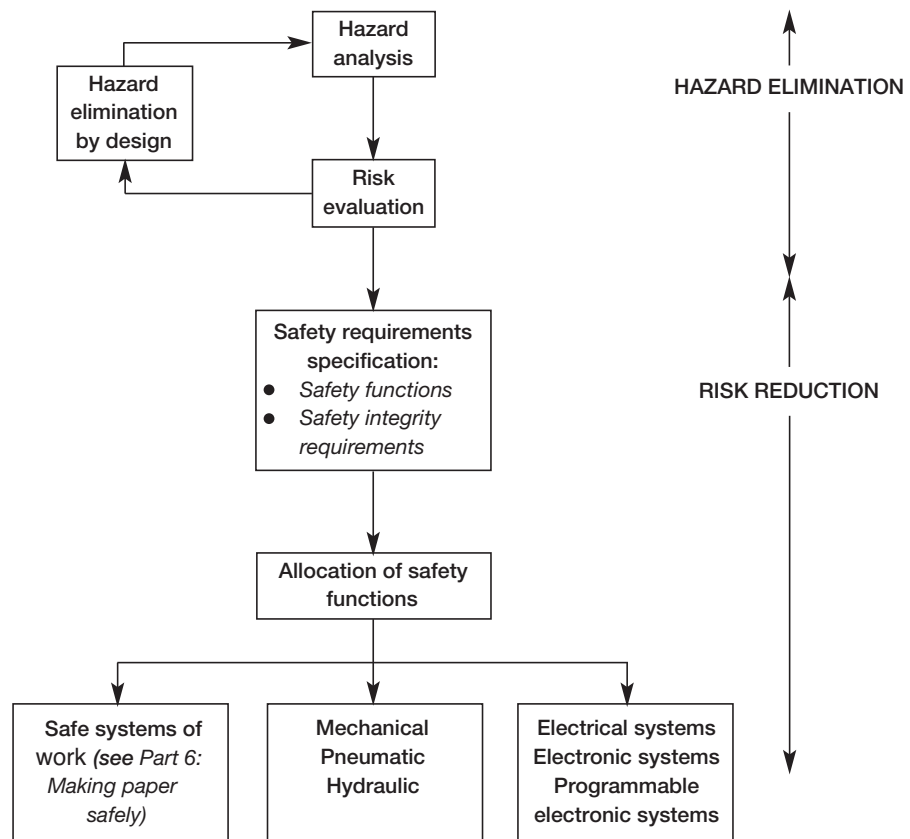

**Figure 31** The risk control process

## Designing safety-related control systems

13 The following points aim to help the process of designing safety-related control systems:

- As part of the risk assessment exercise, determine which of the measures relies on a safety-related control system.
- For each safety function, determine the contribution required from the safety-related control system to achieve the necessary level of risk reduction.
- Draw up the safety requirements specification that relates the required safety integrity to each of the safety functions.
- Design the system, including the safety-related system.
- Validate the design to ensure that it meets the safety requirements specification. This should include consideration of the consequences of failures and may require the application of failure mode and effects analysis (FMEA) to the control circuits to determine the behaviour under fault conditions. (In the simplest form of FMEA, the question ‘What happens if a particular part fails to function as intended?’ is asked.) The design should consider failures within purpose-built control units, such as electronic motor drives and any external to the drives.
- Document the process so that anyone who needs to can understand how and why the system meets the safety requirements.

14 These points are applicable to new machines, machines being refurbished to present-day standards and to older machines being reassessed for the purpose of improving safety.

## Use of standards for safety-related control systems

15 Although the use of standards is not mandatory, there are a number of standards on safety-related systems available that provide relevant guidance, the main two being BS EN ISO 13849-1 and BS EN 62061.<sup>20</sup> It is essential that designers are competent to use these standards when applying their principles in practice.

16 The transposed harmonised standard BS EN ISO 13849-1 provides requirements by which the safety-related parts of control systems of all operating media can be analysed in a qualitative and quantitative manner.

17 Guidance on the processes and procedures appropriate to the design and development of electrical, electronic and programmable electronic technology-based safety-related control systems is set out in BS EN 62061.

18 Machinery designers and/or control systems integrators should decide on the appropriate standard that can be applied to the safety-related control circuits.

19 BS EN ISO 13849-1 is a development of BS EN 954-1 which has now been withdrawn. It extends the provisions of BS EN 954 to include the principles of functional safety found in the basic safety publication BS EN 61508.<sup>21</sup>

20 BS EN ISO 13849-1 contains information on the system hardware and software architectures aimed at achieving an adequate level of safety integrity. The ability of a safety-related control system to perform a safety function under foreseeable conditions is allocated one of five levels, called performance levels (PL). These performance levels are defined in terms of probability of dangerous failure per hour (see Table 1). The probability of dangerous failure of the safety function depends on several factors, including:

- hardware and software structure;
- the extent of fault detection mechanisms;
- reliability of components;
- common cause failure;
- the design process;
- operating stress;
- environmental conditions; and
- operation procedures.

21 The initial risk assessment process determines the PL of a safety function, the analysis of the machine's safety requirements and the level of risk considered acceptable in the specific application. It is essential that this analysis is carried out by a competent person.



**Table 1** Performance levels in terms of probability of dangerous failure per hour

PL	Average probability of dangerous failure per hour
e	$\geq 10^{-8}$ to $< 10^{-7}$
d	$\geq 10^{-7}$ to $< 10^{-6}$
c	$\geq 10^{-6}$ to $< 3 \times 10^{-6}$
b	$\geq 3 \times 10^{-6}$ to $< 10^{-5}$
a	$\geq 10^{-5}$ to $< 10^{-4}$

22 The PL assigned to each safety function in a safety-related control system has a strong influence on the requirements that have to be taken into account during its design and integration. These measures, together with the calculation of failure rates for the safety functions, are an integral part of the process of achieving a safe design.

23 BS EN ISO 13849-1 retains the concept of Categories from BS EN 954 but this concept has been modified to relate to specific control systems architectures and specified behaviours under fault conditions. These Categories are allocated one of five levels, termed Categories B, 1, 2, 3 and 4. Besides specifying a specific PL, machinery designers and/or control systems integrators may also wish to assign a specific Category to a safety function in order to achieve the desired system fault tolerance. Annex A of BS EN ISO 13849-1 contains guidance for the determination of required PLs for allocation to safety functions.

24 BS EN 62061 is the machinery sector implementation of BS EN 61508. It provides machine designers with guidance on how to develop and validate safety-related electrical, electronic and programmable electronic control systems.

25 BS EN 62061 contains information on the system hardware and software architectures aimed at achieving an adequate level of safety integrity. A quantitative analysis concept in BS EN 62061 is that of safety integrity levels (SILs), which specify the failure rate for each safety function. The initial risk assessment process determines the SIL of a safety function, the analysis of the machine's safety requirements and the level of risk considered acceptable in the specific application. It is essential that this analysis is carried out by a competent person.

26 SILs range from SIL1 to SIL4, the latter having the highest level of safety integrity. The failure rates allocated to SIL values are shown in Table 2; this definition of SILs is deemed the most appropriate in machinery safety applications. Annex A of BS EN 62061 contains guidance for the risk estimation and SIL assignment that can be applied to safety functions.

**Table 2** Failure rates allocated to SIL values

SIL	Dangerous failure rate of the safety function (per hour)
4	$\leq 10^{-9}$ to $<10^{-8}$
3	$\leq 10^{-8}$ to $<10^{-7}$
2	$\leq 10^{-7}$ to $<10^{-6}$
1	$\leq 10^{-6}$ to $<10^{-5}$

27 The SIL assigned to each safety function in a safety-related control system has a strong influence on the requirements that have to be taken into account during its design and integration. These measures, together with the calculation of failure rates for the safety-related control systems, are an integral part of the process of achieving a safe design.

### Comparing SILs and PLs

28 The fact that the average probability of dangerous failure per hour in BS EN 13849-1 and the probability of dangerous failure per hour in BS EN 62061 both have the same range of allocated numbers, means that there is a direct relationship between them at this level. However, both standards are written from different perspectives so the additional measures necessary to achieve a SIL or PL may not be equivalent. For this reason, machinery designers and/or control systems integrators should not mix the requirements from one of the standards with those of the other. PD IEC/TR 62061-1:2010<sup>22</sup> provides further information on this issue.

### Testing and preventative maintenance

29 To maintain safety integrity, all safety-related control systems should be tested regularly as part of a preventative maintenance strategy. For any particular safety-related control system, the frequency of testing should be determined taking into account: the required safety integrity; the demand rate on the system; the degree of fault tolerance; and the diagnostic capabilities of the safety-related control systems. For example, consider a machine with an over-speed detection and protection system in which failure of the system could lead to injury in the event of the machine exceeding its maximum speed. It is likely that the demand rate on the safety function (ie prevention of speed above a set value) will be very low in normal operation and its design may be such that a potentially dangerous fault could remain undetected until a demand is placed on the system.

30 In this type of safety-related control system, the overall safety integrity could be improved by arranging for the safety function to be tested as part of a routine maintenance programme at a frequency recommended by the designer, with instructions on the maintenance regime being included in the machine's documentation.

## Modifications to safety-related control systems

31 Typical reasons for modification of a safety-related control system include changes to the conditions of use, incident/accident experience and modification of the machine or its operating modes. The following points are applicable when modifications are being made:

- The proposed modification should be assessed to determine the contribution that the modified safety-related control system will make towards risk reduction. The proposed modification should then be analysed to establish the impact on the hardware and software elements of the safety-related control system. This should include an appropriate review of the failure modes, particularly new failure modes that may be introduced by the modification, and their consequences for safety at the papermaking machine.
- Where it is agreed that a modification can be made without an adverse impact on safety, hardware and software changes to the safety-related control system should be processed within a structured work programme incorporating, as appropriate, specification, design, integration, installation, commissioning and validation.
- The changes made to the safety-related control system should be documented and marked with appropriate version numbers and dates.
- Before re-instating the papermaking machine into normal operation, it is recommended that the modification work be reviewed by a competent person to ensure that the work has been properly implemented.

## Programmable electronic safety-related control systems

32 In general, programmable electronic safety-related control systems on papermaking machines should make use of devices that have been specifically designed and assessed for use in safety-related applications. General industrial programmable logic controllers (PLC), or general-purpose computers and similar devices will usually not have enough safety integrity for safety-related applications unless additional measures are employed to protect against failure, and the overall arrangements are assessed against relevant standards.

33 The safety integrity level (SIL) or performance level (PL) claimed for any PLC or similar device that has been supplied for use in safety-related applications should be equal to that of the most critical safety function that it performs. For papermaking machines, it is recommended that single PLCs and similar programmable devices used in safety-related applications should, in themselves, be capable of satisfying the requirements of SIL3 in accordance with BS EN 62061 or PLe in accordance with BS EN ISO 13849-1.

34 Programmable safety-related control systems contain software components so, as well as considering the design features needed to control the effects of random hardware failures, the designer must take steps to ensure that the software does not contain faults, known as systematic faults, that can lead to danger. Since it is generally recognised that software cannot be tested with enough confidence to detect all such faults, the preferred approach to minimising the likelihood of errors being introduced during the specification and development of the safety-related software is to ensure that the project is well managed within a structured framework, with progressive verification and validation of the software components throughout the development cycle, including final development work during commissioning activities. It is strongly recommended that such work be carried out within a formal quality control system.

35 Within this structured framework, the accuracy and completeness of the initial specification for the requirements for safety performance in the control system is of fundamental importance. If the initial specification is at all deficient, the follow-on stages in the development cycle will not prevent systematic faults from being inadvertently introduced, regardless of how rigorously they are implemented.

36 A programmable safety-related control system at a papermaking machine may also include non-programmable technologies, such as electrical and electronic parts (eg gate switches, transposing relays etc). These parts may have assigned safety performance categories to BS EN 954-1:1997 (which is now withdrawn) or performance levels/safety integrity levels to BS EN ISO 13849-1/BS EN 62061.

37 Before they are integrated into a programmable safety-related control system, it is important that the designer/integrator is able fully to determine whether their application will allow the safety function to achieve the appropriate SIL/PL in accordance with the relevant standard.

38 It is essential that work on the specification, design and development of programmable safety-related control systems is carried out by people who are competent in this particular field and who, in particular, are skilled in the concepts of capturing safety requirements, safety validation, safety-related system architecture design, hardware and software realisation and project safety assurance. The Institution of Electrical Engineers, in conjunction with the British Computer Society has published guidance on the competence requirements for people working in this field.

### **Non-programmable safety-related control systems**

39 This type of safety-related control system does not contain programmable electronic parts, although it is recognised that systems implemented in non-programmable technologies may in themselves be quite complex in nature. They can include electromechanical relay-based systems, hydraulic and pneumatic systems and mechanical systems that can be assessed using deterministic principles.

40 The general principles for the design of these systems are similar to those used for programmable electronic systems. This is because the requirements should be based on a fundamental assessment of the risks created by the machine and the extent to which the safety-related control system is needed to reduce those risks to an acceptable level, taking into account all other measures taken to control the level of risk.

### **Particular safety functions on papermaking machines**

41 There are three particular safety functions on papermaking machinery that need to be given careful consideration – emergency stop, the speed-control system and pre-start warning device. There can be many other safety functions that will also need to be considered, including guard interlocking and hold-to-run control.

#### ***Emergency stop***

42 The emergency stop function should be designed in accordance with BS EN 60204-1<sup>23</sup> and BS EN ISO 13850.<sup>24</sup> Stopping categories 0 or 1 may be used. Adequate environmental protection of the system hardware should be provided to reduce the probability of dangerous failures.

43 Since an emergency stop circuit can remain inactive for long periods of time, it is important that the reliability and architecture of the design solution, and the maintenance and testing requirements are such that there is a high confidence that it will function effectively on demand.

44 The emergency stop function should not be reliant on the correct operation of a machine control system that deals with other safety functions, and where unrevealed failures in the control system would negate the operation of the emergency stop functions. In such cases, an independent emergency stop control system should be provided.

### ***Speed-control system***

45 The risks that occur in the event of over-speed at a machine arising from control system failure can be significant, particularly when the operator is working inside the hazardous area, for example to remove broke. The use of a hold-to-run or enabling device by the operator or an accompanying person will not eliminate the risks completely, so the control system should be designed, or modified, to minimise the risk of injury from:

- unexpected increase in crawl speed, hold-to-run speed or other pre-set low speed;
- unexpected start-up while machines are held at stop condition by the control system only, ie a Category 2 stop as described in EN 60204-1.

46 Where reasonably practicable, to recognise a deviation from a set speed condition where danger could arise (including zero speed), design options should include one or more of the following:

- monitoring techniques to enhance the safety features of the speed set point control circuitry and the reliability of the speed detection devices. Dangerous deviations detected by monitoring should initiate a safe stop;
- a speed reference tachometer/encoder/motion transducer or overspeed trip/detection device automatically set for use during slow speed or stop; conditions. Activation should initiate a safe stop;
- allow more time for machine operators to react by, for example:
  - modifying the acceleration or current limit control signals;
  - modifying inertia compensation control signals.

### ***Pre-start warning device***

47 Failure of a pre-start warning device could result in the machine being started before the waiting time has elapsed (ie people would not have enough time to leave a hazardous area on hearing the alarm) or the machine could be started up without a warning being sounded.

48 The aim should be to ensure that the pre-start warning system would have very high reliability and availability and be effective so that the warning signals can be recognised by all personnel who would be exposed to danger when machines are started.

49 The control system safety reliability considerations should include:

- monitoring of components so that recognised failures will prevent start-up;
- applying redundancy techniques to the safety critical parts of the warning system.

50 The effectiveness considerations should include:

- selecting the audible warning, or other warning indication device (including voice messages) so that it is easily understood by the workforce at risk, taking account of hearing impairment from medical conditions or use of hearing protection (PPE);
- where there are a number of separate machines, ensuring that each warning device dedicated to a particular machine is easily recognised by those at risk from the particular machine.

# Acknowledgements

## Members of the working group

Julie Westcott	DS Smith
Andy Braund	Confederation of Paper Industries
Colin Popplewell	SCA Hygiene
Gary Seager	UNITE the Union
Bud Hudspith	UNITE the Union
Derek Simpson	UNITE the Union
Julie Stevens	Smurfit Kappa
George Craig	De La Rue Currency
Neil Sinar	De La Rue Currency
Kirsty Storer	Health and Safety Executive
Steve Shaw	Health and Safety Executive
Dave Bromme	Pilz Automation Technology

# References and further reading

## References

- 1 *Safe use of work equipment. Provision and use of Work Equipment Regulations 1998. Approved Code of Practice and guidance L22* (Fourth edition) HSE Books 2014 ISBN 978 0 7176 6619 5 [www.hse.gov.uk/pubns/books/l22.htm](http://www.hse.gov.uk/pubns/books/l22.htm)
- 2 *Reducing error and influencing behaviour* HSG48 (Second edition) HSE Books 1999 ISBN 978 0 7176 2452 2 [www.hse.gov.uk/pubns/books/hsg48.htm](http://www.hse.gov.uk/pubns/books/hsg48.htm)
- 3 BS EN ISO 13857:2008 *Safety of machinery. Safety distances to prevent hazard zones being reached by upper and lower limbs* British Standards Institution
- 4 BS EN 953:1997 *Safety of machinery. Guards. General requirements for the design and construction of fixed and movable guards* British Standards Institution
- 5 BS EN ISO 12100:2010 *Safety of machinery. General principles for design. Risk assessment and risk reduction* British Standards Institution
- 6 BS EN 1034-1:2000 *Safety of machinery. Safety requirements for the design and construction of paper-making and finishing machines. Common requirements* British Standards Institution
- 7 BS EN 574:1996 *Safety of machinery. Two-hand control devices. Functional aspects. Principles for design* British Standards Institution
- 8 *Managing Contractors: A guide for employers* HSG159 (Second edition) HSE Books 2011 ISBN 978 0 7176 6436 8 [www.hse.gov.uk/pubns/books/hsg159.htm](http://www.hse.gov.uk/pubns/books/hsg159.htm)
- 9 *Using Contractors: A brief guide* Leaflet INDG368(rev1) HSE Books 2013 [www.hse.gov.uk/pubns/indg368.htm](http://www.hse.gov.uk/pubns/indg368.htm)
- 10 *The Work at Height Regulations 2005* SI 2005/735 The Stationery Office [www.legislation.gov.uk](http://www.legislation.gov.uk)
- 11 *Safe work in confined spaces. Confined Spaces Regulations 1997. Approved Code of Practice, Regulations and guidance L101* (Third edition) HSE Books 2014 ISBN 978 0 7176 6622 5 [www.hse.gov.uk/pubns/books/l101.htm](http://www.hse.gov.uk/pubns/books/l101.htm)
- 12 BS EN 1034-16:2012 *Safety of machinery. Safety requirements for the design and construction of paper-making and finishing machines. Paper- and board-making machines* British Standards Institution
- 13 *Safe use of lifting equipment. Lifting Operations and Lifting Equipment Regulations 1998. Approved Code of Practice and guidance L113* (Second edition) HSE Books 2014 ISBN 978 0 7176 6586 0 [www.hse.gov.uk/pubns/books/l113.htm](http://www.hse.gov.uk/pubns/books/l113.htm)
- 14 *Working at height: A brief guide* Leaflet INDG401(rev2) HSE Books 2014 [www.hse.gov.uk/pubns/indg401.htm](http://www.hse.gov.uk/pubns/indg401.htm)
- 15 BS EN 1034-13:2005 *Safety of machinery. Safety-related parts of control systems. General principles for design* British Standards Institution
- 16 BS EN ISO 13849-1:2008 *Safety of machinery. Safety-related parts of control systems. General principles for design* British Standards Institution



- 17 *Dangerous substances and explosive atmospheres: Dangerous Substances and Explosive Atmospheres Regulations 2002. Approved Code of Practice and guidance L138* (Second edition) HSE Books 2013 ISBN 978 0 7176 6616 4 [www.hse.gov.uk/pubns/books/l138.htm](http://www.hse.gov.uk/pubns/books/l138.htm)
- 18 BS EN ISO 14119:2013 *Safety of machinery. Interlocking devices associated with guards. Principles for design and selection* British Standards Institution
- 19 *Safety of pressure systems. Pressure Systems Safety Regulations 2000. Approved Code of Practice and guidance L122* (Second edition) HSE Books 2014 ISBN 978 0 7176 6644 7 [www.hse.gov.uk/pubns/books/l122.htm](http://www.hse.gov.uk/pubns/books/l122.htm)
- 20 BS EN 62061:2005 *Safety of machinery. Functional safety of safety-related electrical, electronic and programmable electronic control systems* British Standards Institution
- 21 BS EN 61508:2010 *Functional safety of electrical/electronic/programmable electronic safety-related systems. General requirements* British Standards Institution
- 22 PD IEC/TR 62061-1:2010 *Guidance on the application of ISO 13849-1 and IEC 62061 in the design of safety-related control systems for machinery* British Standards Institution
- 23 BS EN 60204-1:2006 *Safety of machinery. Electrical equipment of machines. General requirements* British Standards Institution
- 24 BS EN ISO 13850:2008 *Safety of machinery. Emergency stop. Principles for design* British Standards Institution

### **Further reading**

- 1 *Work with ionising radiation. Ionising Radiations Regulations 1999. Approved Code of Practice and guidance L121* HSE Books 2000 ISBN 978 0 7176 1746 3 [www.hse.gov.uk/pubns/books/l121.htm](http://www.hse.gov.uk/pubns/books/l121.htm)
- 2 *Buying new machinery: A short guide to the law and your responsibilities when buying new machinery for use at work* Leaflet INDG271(rev1) HSE 2011 [www.hse.gov.uk/pubns/indg271.htm](http://www.hse.gov.uk/pubns/indg271.htm)
- 3 *Risk assessment: A brief guide to controlling risks in the workplace* Leaflet INDG163(rev4) HSE Books 2014 [www.hse.gov.uk/pubns/indg163.htm](http://www.hse.gov.uk/pubns/indg163.htm)
- 4 *Confined spaces: A brief guide to working safely* Leaflet INDG258(rev1) HSE Books 2013 [www.hse.gov.uk/pubns/indg258.htm](http://www.hse.gov.uk/pubns/indg258.htm)
- 5 *Manual handling. Manual Handling Operations Regulations 1992 (as amended). Guidance on Regulations L23* (Third edition) HSE Books 2004 ISBN 978 0 7176 2823 0 [www.hse.gov.uk/pubns/books/l23.htm](http://www.hse.gov.uk/pubns/books/l23.htm)
- 6 *STEP: Slips and trips eLearning Package* HSE 2008 [www.hse.gov.uk/slips/step/](http://www.hse.gov.uk/slips/step/)
- 7 *Workplace health, safety and welfare. Workplace (Health, Safety and Welfare) Regulations 1992. Approved Code of Practice and guidance L24* (Second edition) HSE Books 2013 ISBN 978 0 7176 6583 9 [www.hse.gov.uk/pubns/books/l24.htm](http://www.hse.gov.uk/pubns/books/l24.htm)

- 8 *Compressed air safety* HSG39 (Second edition) HSE Books 1998  
ISBN 978 0 7176 1531 5 [www.hse.gov.uk/pubns/books/hsg39.htm](http://www.hse.gov.uk/pubns/books/hsg39.htm)
- 9 *Lighting at work* HSG38 (Second edition) HSE Books 1998  
ISBN 978 0 7176 1232 1 [www.hse.gov.uk/pubns/books/hsg38.htm](http://www.hse.gov.uk/pubns/books/hsg38.htm)
- 10 *Personal protective equipment at work. Personal Protective Equipment at Work Regulations 1992 (as amended). Guidance on Regulations L25* (Second edition)  
HSE Books 2005 ISBN 978 0 7176 6139 8 [www.hse.gov.uk/pubns/books/l25.htm](http://www.hse.gov.uk/pubns/books/l25.htm)
- 11 *Workplace transport safety: A brief guide* Leaflet INDG199(rev2) HSE Books  
2013 [www.hse.gov.uk/pubns/indg199.htm](http://www.hse.gov.uk/pubns/indg199.htm)
- 12 *A guide to workplace transport safety* HSG136 (Third edition) HSE 2014  
[www.hse.gov.uk/pubns/hsg136.htm](http://www.hse.gov.uk/pubns/hsg136.htm)
- 13 *Controlling noise at work. The Control of Noise at Work Regulations 2005. Guidance on Regulations L108* (Second edition) HSE Books 2005  
ISBN 978 0 7176 6164 0 [www.hse.gov.uk/pubns/l108.htm](http://www.hse.gov.uk/pubns/l108.htm)
- 14 *Managing for health and safety* HSG65 (Third edition) HSE Books 2013  
ISBN 978 7176 6456 6 [www.hse.gov.uk/pubns/hsg65.htm](http://www.hse.gov.uk/pubns/hsg65.htm)
- 15 *Managing for health and safety website* [www.hse.gov.uk/managing/index.htm](http://www.hse.gov.uk/managing/index.htm)



## Further information

For information about health and safety, or to report inconsistencies or inaccuracies in this guidance, visit [www.hse.gov.uk/](http://www.hse.gov.uk/). You can view HSE guidance online and order priced publications from the website. HSE priced publications are also available from bookshops.

British Standards can be obtained in PDF or hard copy formats from BSI: <http://shop.bsigroup.com> or by contacting BSI Customer Services for hard copies only Tel: 0845 086 9001 email: [cservices@bsigroup.com](mailto:cservices@bsigroup.com).

The Stationery Office publications are available from The Stationery Office, PO Box 29, Norwich NR3 1GN Tel: 0870 600 5522 Fax: 0870 600 5533 email: [customer.services@tso.co.uk](mailto:customer.services@tso.co.uk) Website: [www.tsoshop.co.uk](http://www.tsoshop.co.uk). (They are also available from bookshops.) Statutory Instruments can be viewed free of charge at [www.legislation.gov.uk](http://www.legislation.gov.uk) where you can also search for changes to legislation.

This guidance is issued by the Health and Safety Executive. Following the guidance is not compulsory, unless specifically stated, and you are free to take other action. But if you do follow the guidance you will normally be doing enough to comply with the law. Health and safety inspectors seek to secure compliance with the law and may refer to this guidance.

This document is available at: [www.hse.gov.uk/pubns/books/hsg279.htm](http://www.hse.gov.uk/pubns/books/hsg279.htm).

© *Crown copyright* If you wish to reuse this information visit [www.hse.gov.uk/copyright.htm](http://www.hse.gov.uk/copyright.htm) for details. First published 06/15.